



**PRO**

**GBS18V-75**

Robert Bosch Power Tools GmbH  
70538 Stuttgart  
GERMANY

[www.bosch-pt.com](http://www.bosch-pt.com)

1 609 92A D3Y (2026.02) 0 / 19



1 609 92A D3Y

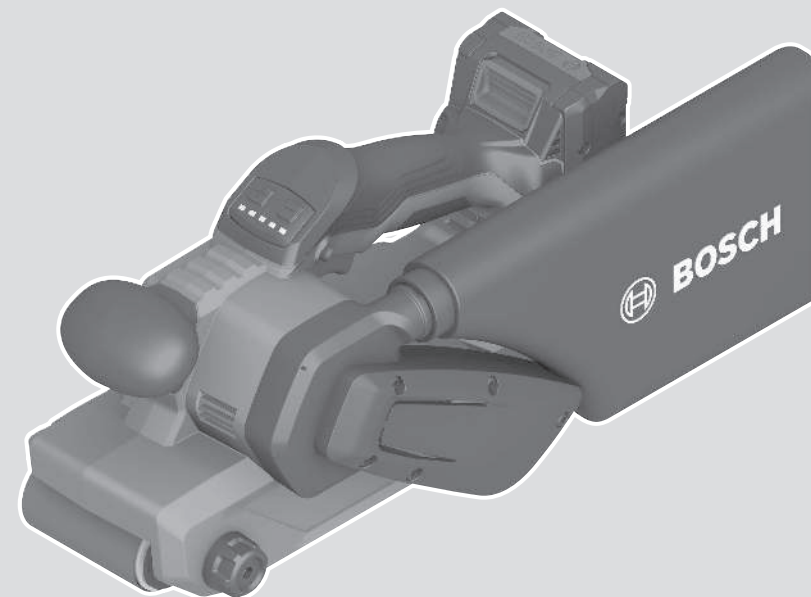

zh 正本使用说明书





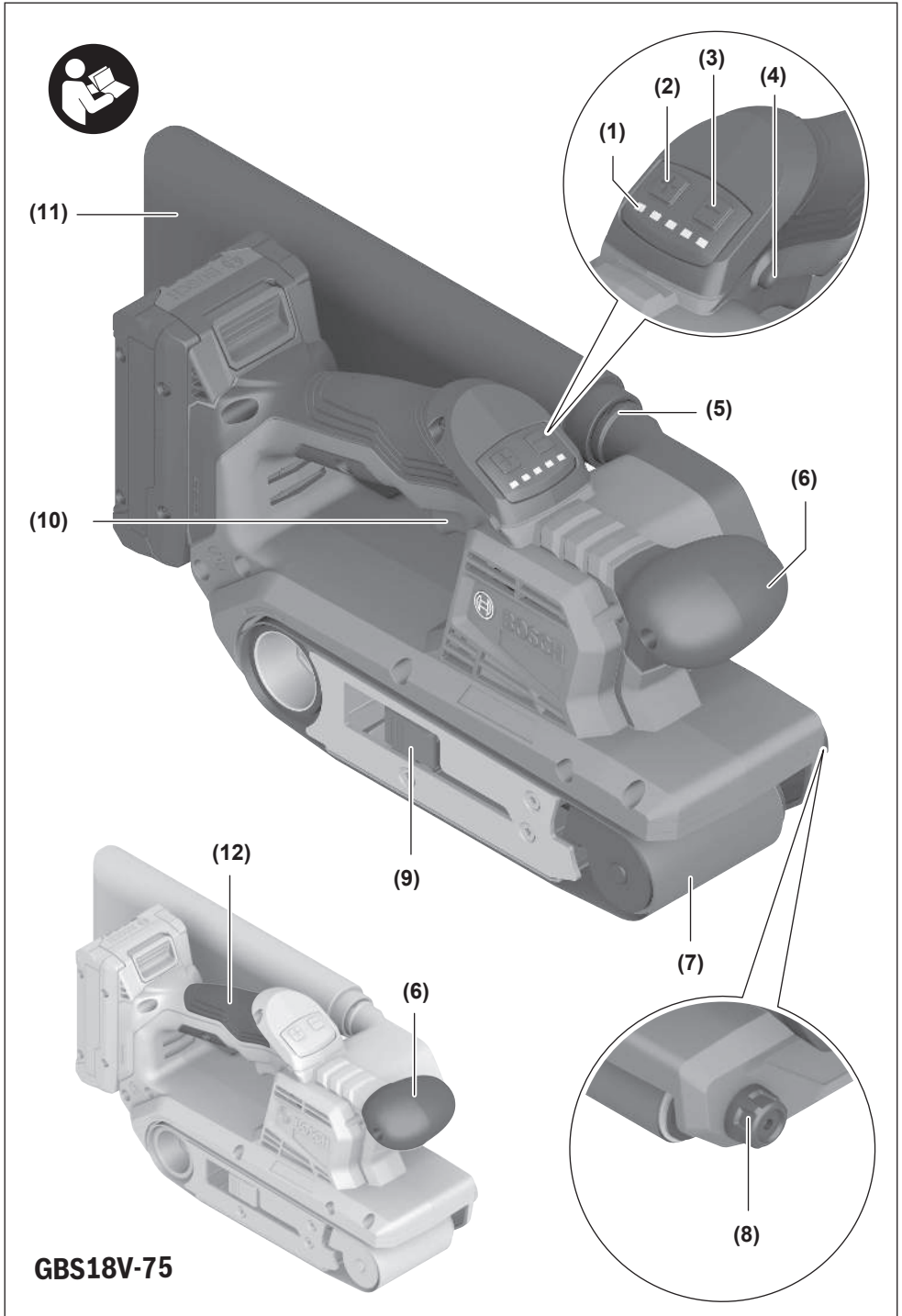

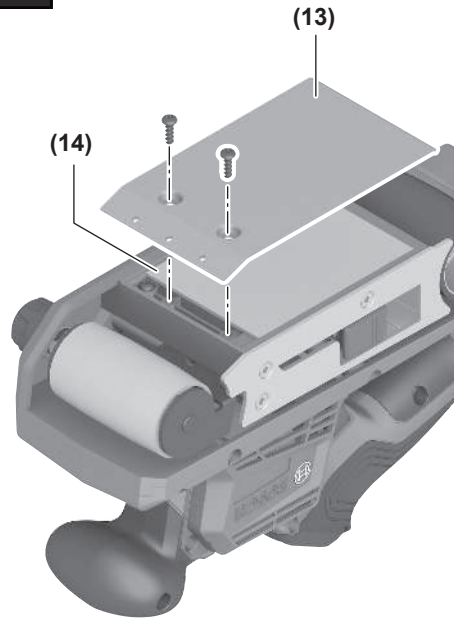
**A****B****C**

# 中文

## 安全规章

### 电动工具通用安全警告

#### ⚠ 警告！

阅读随电动工具提供的所有安全警告、说明、图示和规定。

不遵照以下所列说明会导致电击、着火和/或严重伤害。

保存所有警告和说明书以备查阅。

警告中的术语“电动工具”是指市电驱动（有线）电动工具或电池驱动（无线）电动工具。

#### 工作场地的安全

- ▶ 保持工作场地清洁和明亮。杂乱和黑暗的场地会引发事故。
- ▶ 不要在易爆环境，如有易燃液体、气体或粉尘的环境下操作电动工具。电动工具产生的火花会点燃粉尘或气体。
- ▶ 操作电动工具时，远离儿童和旁观者。注意力不集中会使你失去对工具的控制。

#### 电气安全

- ▶ 电动工具插头必须与插座相配。绝不能以任何方式改装插头。需接地的电动工具不能使用任何转换插头。未经改装的插头和相配的插座将降低电击风险。
- ▶ 避免人体接触接地表面，如管道、散热片和冰箱。如果你身体接触接地表面会增加电击风险。
- ▶ 不得将电动工具暴露在雨中或潮湿环境中。水进入电动工具将增加电击风险。
- ▶ 不得滥用软线。绝不能用软线搬运、拉动电动工具或拔出其插头。使软线远离热源、油、锐边或运动部件。受损或缠绕的软线会增加电击风险。
- ▶ 当在户外使用电动工具时，使用适合户外使用的延长线。适合户外使用的电线将降低电击风险。
- ▶ 如果无法避免在潮湿的环境中操作电动工具，应使用带有剩余电流装置（RCD）保护的电源。RCD的使用可降低电击风险。

#### 人身安全

- ▶ 保持警觉，当操作电动工具时关注所从事的操作并保持清醒。当你感到疲倦，或在有药物、酒精或治疗反应时，不要操作电动工具。在操作电动工具时瞬间的疏忽会导致严重人身伤害。
- ▶ 使用个人防护装置。始终佩戴护目镜。防护装置，诸如适当条件下使用防全面具、防滑安全鞋、安全帽、听力防护等装置能减少人身伤害。
- ▶ 防止意外起动。在连接电源和/或电池包、拿起或搬运工具前确保开关处于关断位置。手指放在开关上搬运工具或开关处于接通时通电会导致危险。
- ▶ 在电动工具接通之前，拿掉所有调节钥匙或扳手。遗留在电动工具旋转零件上的扳手或钥匙会导致人身伤害。

- ▶ 手不要过分伸展。时刻注意立足点和身体平衡。这样能在意外情况下能更好地控制住电动工具。
- ▶ 着装适当。不要穿宽松衣服或佩戴饰品。让你的头发和衣服远离运动部件。宽松衣服、配饰或长发可能会卷入运动部件。
- ▶ 如果提供了与排屑、集尘设备连接用的装置，要确保其连接完好且使用得当。使用集尘装置可降低尘屑引起的危险。
- ▶ 不要因为频繁使用工具而产生的熟悉感而掉以轻心，忽视工具的安全准则。某个粗心的动作可能在瞬间导致严重的伤害。

#### 电动工具使用和注意事项

- ▶ 不要勉强使用电动工具，根据用途使用合适的电动工具。选用合适的按照额定值设计的电动工具会使你工作更有效、更安全。
- ▶ 如果开关不能接通或关断电源，则不能使用该电动工具。不能通过开关来控制的电动工具是危险的且必须进行修理。
- ▶ 在进行任何调节、更换附件或贮存电动工具之前，必须从电源上拔掉插头和/或卸下电池包（如可拆卸）。这种防护性的安全措施降低了电动工具意外起动的风险。
- ▶ 将闲置不用的电动工具贮存在儿童所及范围之外，并且不允许不熟悉电动工具和不了解这些说明的人操作电动工具。电动工具在未经培训的使用者手中是危险的。
- ▶ 维护电动工具及其附件。检查运动部件是否调整到位或卡住，检查零件破损情况和影响电动工具运行的其他状况。如有损坏，应在使用前修理好电动工具。许多事故是由维护不良的电动工具引发的。
- ▶ 保持切削刀具锋利和清洁。维护良好地有锋利切削刃的刀具不易卡住而且容易控制。
- ▶ 按照使用说明书，并考虑作业条件和要进行的作业来选择电动工具、附件和工具的刀头等。将电动工具用于那些与其用途不符的操作可能会导致危险情况。
- ▶ 保持手柄和握持表面干燥、清洁，不得沾有油脂。在意外的情况下，湿滑的手柄不能保证握持的安全和对工具的控制。

#### 电池式工具使用和注意事项

- ▶ 仅使用生产者规定的充电器充电。将适用于某种电池包的充电器用到其他电池包时可能会发生着火危险。
- ▶ 仅使用配有专用电池包的电动工具。使用其他电池包可能会产生伤害和着火危险
- ▶ 当电池包不用时，将它远离其他金属物体，例如回形针、硬币、钥匙、钉子、螺钉或其他小金属物体，以防电池包一端与另一端连接。电池组端部短路可能会引起燃烧或着火。
- ▶ 在滥用条件下，液体可能会从电池组中溅出；应避免接触。如果意外碰到液体，用水冲洗。如果液体碰到了眼睛，还应寻求医疗帮助。从电池中溅出的液体可能会发生腐蚀或燃烧。

- ▶ **不要使用损坏或改装过的电池包或工具。**损坏或改装过的电池组可能呈现无法预测的结果，导致着火、爆炸或伤害。
- ▶ **不要将电池包暴露于火或者高温中。**电池包暴露于火或高于 130 °C 的高温中可能导致爆炸。
- ▶ **遵守所有充电说明，给电池组或工具充电时不要超出说明中规定的温度范围。**错误充电或温度超出规定的范围可能会损坏电池并提高着火的风险。

### 维修

- ▶ **由专业维修人员使用相同的备件维修电动工具。**这将保证所维修的电动工具的安全。
- ▶ **决不能维修损坏的电池包。**电池包仅能由生产者或其授权的维修服务商进行维修。

### 带式砂光机和辊式砂光机安全警告

- ▶ **因砂磨面可能会触及自身软线,要通过绝缘握持面来握持工具。**砂磨到带电导线会使工具外露的金属零件带电而使操作者受到电击。
- ▶ **本电动工具仅可用于干法研磨。**水进入电动工具将增加电击危险。
- ▶ **只有在启动后方可将本电动工具迎向工件，只有将本电动工具从工件上移开后方可将其关闭。**本电动工具可能会突然移动。
- ▶ **切勿触碰正在运行的砂带。**有受伤的危险。
- ▶ **请佩戴防护手套，切勿触碰正在运行的砂带。**有受伤的危险。
- ▶ **要注意确保飞溅的火花不会伤到人。**清除附近的可燃材料。研磨金属时会有火花飞溅。
- ▶ **注意火灾危险！应避免磨料和研磨机过热。**每次工作休息前都要清空集尘腔。集尘袋、微过滤器、纸袋（或者吸尘器的过滤袋或过滤器）内的磨削粉尘可能会在不良条件下（例如研磨金属时火花飞溅）被点燃。如果磨削粉尘与油漆或聚氨酯残余物或者其他化学原料混合，且磨料在长时间作业后产生高温时，会产生极大危险。
- ▶ **定期清洁电动工具的通风间隙。**电动机风扇会将灰尘吸进机壳，过多的金属粉末沉积会导致电气危险。
- ▶ **如果充电电池损坏或者未按照规定使用，充电电池中会散发出有毒蒸汽。充电电池可能会燃烧或爆炸。**工作场所必须保持空气流通，如果身体有任何不适必须马上就医。蒸汽会刺激呼吸道。
- ▶ **切勿改装并打开充电电池。**可能造成短路。
- ▶ **钉子、螺丝刀等尖锐物品或外力作用可能会损坏充电电池。**有可能出现内部短路、蓄电池燃烧、发出烟雾、爆炸或过热。
- ▶ **仅在制造商的产品中使用充电电池。**这样才能确保充电电池不会过载。



保护充电电池免受高温（例如长期阳光照射）、火焰、脏污、水和湿气的侵害。有爆炸和短路的危险。

- ▶ **等待电动工具完全静止后才能够放下机器。**

- ▶ **固定好工件。**使用固定装置或老虎钳固定工件，会比用手持握工件更牢固。

## 产品和性能说明



请阅读所有安全规章和指示。不遵照以下警告和说明可能导致电击、着火和/或严重伤害。

请注意本使用说明开头部分的图示。

### 按照规定使用

本电动工具适合在木材、塑料、金属、填隙料和涂了油漆的表面进行干式平面研磨工作，磨除率高。

### 插图上的机件

机件的编号和电动工具详解图上的编号一致。

- (1) 砂带速度（白色）和充电电池电量（绿色）LED指示灯
- (2) 砂带速度提高键
- (3) 砂带速度降低键
- (4) 电源开关的锁紧键
- (5) 排气孔接头
- (6) 辅助手柄（绝缘握柄）
- (7) 砂带
- (8) 砂带走向调节钮
- (9) 砂带夹紧杆
- (10) 电源开关
- (11) 集尘袋
- (12) 手柄（绝缘握柄）
- (13) 金属板
- (14) 羊毛毡
- (15) 滑板<sup>a)</sup>

a) 该附件并不包含在基本的供货范围中。

### 技术参数

砂带研磨机		GBS18V-75
物品代码		3 601 CC2 0..
额定电压	伏特 <sup>---</sup>	18
砂带空转转速 <sup>A)</sup>	米/分钟	200-320
砂带长度	毫米	533
砂带宽度	毫米	75
砂带速度预选		●
机内吸尘装备/外接吸尘装备的接头		●
Impact Protection (撞击保护装置)		●
撞击检查		●
重启保护		●
恒定电子装置		●
重量 <sup>B)</sup>	公斤	2.7

砂带磨机		GBS18V-75
充电时建议的环境温度	摄氏度	0至+35
工作时和存放时允许的环境温度 <sup>c)</sup>	摄氏度	-20至+50
兼容的充电电池		GBA18V... GBA 18V... ProCORE18V... EXPERT18V... EXBA18V... CORE18V...
推荐的确保全功率的充电电池		ProCORE18V... ≥ 4.0安培小时 EXPERT18V...
推荐的充电器		GAL18... GAL 18... GAL 36... GAL12V/18... GAL 12V/18... GAX 18... EXAL18...

A) 在20-25摄氏度的条件下带充电电池**GBA 18V 4.0Ah**测得

B) 不含充电电池 (充电电池重量请查看 [www.bosch-professional.com](http://www.bosch-professional.com))

C) 温度<0摄氏度时功率受限

数值可能因不同产品而异，并且受到应用和环境条件影响。更多信息请参见[www.bosch-professional.com/wac](http://www.bosch-professional.com/wac)。

## 砂带速度

利用两个砂带速度预选键**(2)**和**(3)**也可以在运行过程中预选所需的砂带速度。正确的砂带速度必须视工件材料和工作条件而定，唯有实际操作才能够找出最合适速度。

LED指示灯	[次/分钟]
1个白灯长亮	200
2个白灯长亮	228
3个白灯长亮	257
4个白灯长亮	286
5个白灯长亮	320

使用低砂带速度长时间操作之后，应该让电动工具以最大砂带速度空转约3分钟来帮助机器冷却。

## 撞击断开



一旦撞击到地面，内置的撞击断开功能就会关闭电动工具。

## Impact Protection (撞击保护装置)



设备碰到障碍物时会自动停止。

## 重启保护



重启保护功能可以避免电动工具在供电中断之后突然失控地重新启动。

如需**再次使用**，请将起停开关**(10)**置于已关闭的位置，然后重新接通电动工具。

## 恒定电子装置



电动工具的电子配件可在设置的较大负荷范围内保持恒定的搅拌头转速。由此确保工作功率均匀。

## 充电电池

**Bosch**也销售不带充电电池的充电式电动工具。您可以在包装上查看电动工具的供货范围内是否包含充电电池。

## 为充电电池充电

▶ **请只使用在技术参数中列出的充电器。**只有这些充电器才适用于本电动工具上的锂离子电池。

**提示：**鉴于国际运输规定，锂离子电池充电电池在交货时只完成部分充电。首度使用电动工具之前，必须先充足充电电池的电量以确保充电电池的功率。

## 安装充电电池

将充好电的充电电池推入电池座，直到嵌入。

## 取出充电电池

如需取下充电电池，则请按压解锁按钮，然后拔出充电电池。**在此过程中请勿过度用力。**

充电电池具备双重锁定功能，即使不小心触动了充电电池的解锁按钮，充电电池也不会从机器中掉落下来。只要充电电池安装在电动工具中，就会被弹簧固定在其位置上。

## 充电电池电量指示灯

**提示：**并非每种充电电池型号均具备电量指示灯。充电电池电量指示灯的绿色LED灯显示充电电池的电量。基于安全原因，只能在电动工具静止时检查充电电池的电量。

按压充电电量指示灯按键 $\odot$ 或 $\odot$ ，来显示充电电量。也可以在充电电池取下时操作。

如果按压充电电量指示灯按键后没有LED灯亮起，则说明充电电池损坏，必须进行更换。

用户界面上也会显示充电电池的电量(参见“LED指示灯”，页9)。

充电电池型号**GBA 18V... | GBA18V...**



LED	电量
3个绿灯长亮	60-100 %
2个绿灯长亮	30-60 %
1个绿灯长亮	5-30 %

LED	电量
1个绿灯闪烁	0-5 %

充电电池类型 ProCORE18V... | EXPERT18V... | EXBA18V... | CORE18V...





LED	电量
5个绿灯长亮	80-100 %
4个绿灯长亮	60-80 %
3个绿灯长亮	40-60 %
2个绿灯长亮	20-40 %
1个绿灯长亮	5-20 %
1个绿灯闪烁	0-5 %

## 充电电池损坏风险识别

### EXPERT18V... | EXBA18V...

充电电池电量指示灯的LED除了可以显示充电电池电量之外，还可以显示充电电池损坏的风险。

如需激活该功能，按住电量指示灯按钮3秒钟。充电电池的分析通过充电电池电量指示灯顺序发光来显示。结果以充电电池电量指示灯显示。

 **1个LED:** 充电电池的损坏风险较高。功率和运行时间可能已经降低。建议更换充电电池。

 **5个LED:** 充电电池处于良好状态，损坏风险较低。

**请注意:** 充电电池损坏风险评估功能分两档运行，提供简单的状态评价。充电电池要么被评价为状态良好，要么就是具有较高的损坏风险。不显示电池状态的百分比。

## 如何正确地使用充电电池

保护充电电池，避免湿气和水分渗入。

充电电池必须储存在-20 °C至50 °C的环境中。夏天不得将充电电池搁置在汽车中。

不时地使用柔软、清洁而且干燥的毛刷清洁充电电池的通气孔。

充电后如果充电电池的使用时间明显缩短，代表充电电池已经损坏，必须更换新的充电电池。

请注意有关作废处理的规定。

## 安装

▶ **对电动工具执行任何操作（比如保养、更换刀具等）前需将充电电池从电动工具中取出。**意外操作起停开关可能会造成伤害。

## 吸锯尘/吸锯屑

在没有采取减尘措施的情况下避免作业。

合适的集尘装置或集尘盒/集尘袋可减少有害健康的粉尘污染。工作场地要保持空气流通。原则上要使用合适的呼吸面罩。为确保最佳集尘效果，请在使

用集尘盒时及时清空该盒并定期清洁滤芯。使用集尘器时注意以下提及的要求。请留心并遵守贵国和加工物料有关的法规。

▶ **避免让工作场所堆积过多的尘垢。**尘埃容易被点燃。

### 对吸尘器的要求

推荐的软管额定直径	毫米	<b>28</b>
所需的负压 <sup>A)</sup>	毫巴	≥ <b>220</b>
	百帕	≥ <b>220</b>
所需的流量 <sup>A)</sup>	升/秒	≥ <b>28</b>
	立方米/小时	≥ <b>100.8</b>
所推荐的过滤效率		M级粉尘 <sup>B)</sup>

A) 电动工具吸尘器接口上的功率值

B) 符合IEC/EN 60335-2-69

注意吸尘器的说明书。抽吸功率降低时请中断作业，然后排查原因。

### 利用集尘袋自集尘

针对小范围操作可以连接集尘袋（附件）**(11)**。将集尘袋接头牢固地插到吸尘器转换接口**(5)**上。请及时清空集尘袋**(11)**，以便保持最佳的集尘效果。

### 外部集尘

将集尘软管插到吸尘器转换接口**(5)**上。

将集尘软管与吸尘器连接。在本使用说明书的末尾可以找到各种集尘器的连接概览。

根据工件的物料选择合适的吸尘装置。

吸尘可能危害健康，可能导致癌症或干燥的废尘时，务必使用特殊的吸尘装置。

## 更换砂带（参见插图A）

- 将夹紧杆**(9)**完全转出。此时砂带**(7)**已经被松开，可以取出。
- 放上新砂带**(7)**。请注意，砂带内侧和电动工具外壳上的箭头方向应一致。
- 将夹紧杆**(9)**再次转回初始位置。
- 提起电动工具并接通电动工具。砂带走向将在开机时以及研磨过程期间自动对中。

请注意，砂带**(7)**不得摩擦壳体。请定期检查砂带走向，必要时用调节钮**(8)**修正走向。

### 选择砂带

根据要加工的材料和需要的表面磨除量提供不同的砂带：

	目数
<b>red:Wood</b>	<b>40-320</b>
用于加工所有木质材料	
对于初磨，例如粗磨、未刨光的方木和木板	粗 40, 60
用于平面打磨和磨平轻微的不平整表面	中 80, 100, 120, 150

## 目数

在硬木上做最后的研磨和精磨工	细	180,
作		220,
		280,
		320

## 运行

## 投入使用

## 接通/关闭

► 请确保握住手柄时可以开启/关闭开关。

如要接通电动工具，请按压电源开关(10)并按住。如需锁定电源开关(10)，请按住该开关并另外按压锁定按钮(4)。

要关闭电动工具，松开电源开关(10)。电源开关(10)锁住时，先按压，然后再松开。

## LED指示灯

以下表格说明可能的LED指示灯(1)。

颜色	状态	含义/原因	解决方案
白色	长亮 (1个~5个灯)	砂带速度	(参见“砂带速度”，页 7)
绿色	长亮 (2个~5个灯)	充电电池已充电	(参见“充电电池电量指示灯”，页 7)
黄色	长亮 (1个灯)	充电电池的电量几乎耗尽(参见“充电电池电量指示灯”，页 7)	尽快更换充电电池或为其充电
	长亮 (5个灯)	已达到临界温度(电机、电子系统、充电电池)	让电动工具空转、冷却
红色	长亮 (1个灯)	充电电池的电量用尽了(参见“充电电池电量指示灯”，页 7)	更换充电电池或为其充电
	长亮 (5个灯)	电动工具发生系统故障(撞击断开、撞击检查或卡住)	重启电动工具或取出充电电池然后装入。

## 预选砂带速度

通过砂带速度提高键(2)可以提高砂带速度，通过砂带速度降低键(3)则将其降低。也可以在运行期间预选所需的砂带速度。

亮起的LED	砂带速度
1-2	低
1-4	中

## 亮起的LED

## 砂带速度

1-5

高

正确的振荡次数是由工件和工作条件决定，唯有实际操作才能够找出最合适的振荡次数。

恒定电子装置可在怠速和负载时保持振频几乎恒定，确保功率均匀。

使用低振荡次数长期操作之后，应该让电动工具以最大振荡次数空运转约3分钟来帮助机器冷却。

## 应用概览

	应用/材料	磨料	转速等级
磨除	- 磨除旧颜料和油漆	P60-P100	3-5
	- 打磨木材		
	- 打磨热塑性塑料	P60-P100	1-3
中间打磨	- 在上漆前打磨木材和木片	P120-P180	4-5
	- 木制工件倒棱		
	- 在酸洗前修平木质表面		
	- 油漆中间打磨和打磨底漆	P220-P280	1-3
精磨	- 边缘油漆中间打磨		
	- 打磨木材	P150-P180	4-5
	- 打磨实木和木片边缘		
	- 在酸洗过的平面和边缘上打磨油漆	P240-P320	1-3

## 工作提示

研磨时的磨除率和工件表面质量主要由所选砂带以及预选的砂带速度决定。砂带的转速越高，磨除率越大，研磨后的工件表面越细。

使用完好的砂带才能够确保研磨功率，并且保护电动工具。

尽可能使用较小的下压力操作电动工具，以便提高砂带的使用寿命。电动工具的自重足以产生优异的研磨功率。过度下压机噐不仅无法提高研磨功率，反而会加重电动工具和砂带的磨损。

把已接通的电动工具放在工件的表面上。轻轻地推进机器，磨轨必须彼此平行，互相重叠。必须顺着木材纤维的走向研磨，磨轨如果和木材纤维的走向交叉，会破坏研磨效果。

特别在磨除残留的油漆时，可能会造成油漆熔化和沾污工件表面和砂带。因此请配合吸尘装置工作。

不得使用研磨过金属的砂带去研磨其他物料。

请只使用Bosch原装研磨附件。

储放砂带时务必吊起砂带，不可以弯折砂带，经过弯折的砂带无法继续使用。

研磨较大的木材表面时，如果使用研磨框（附件），不仅研磨均匀而且可以设定磨除量。

## 维修和服务

### 保养和清洁

▶ 对电动工具执行任何操作（比如保养、更换刀具等）前需将充电电池从电动工具中取出。意外操作起停开关可能会造成伤害。

▶ 电动工具和通气孔必须随时保持清洁，以确保工作效率和工作安全。

使用刷子清除附着在工件上的磨尘。

### 更换金属板（参见插图B）

将金属板(13)拧入羊毛毡(14)，可实现最佳的研磨效果。

金属板(13)出现和使用强度有关的磨损。更换金属板(13)时将砂带(7)取下。拧下金属板(13)，然后将其更换。

放入砂带后调节砂带走向（参见“更换砂带（参见插图A）”，页8）。

### 更换滑板（附件）（参见插图C）

将滑板(15)（附件）拧入金属板(13)，可实现最佳的研磨效果。

滑板(15)出现和使用强度有关的磨损。更换滑板(15)时将砂带(7)取下。拧下滑板(15)，然后将其更换。

放入砂带后调节砂带走向（参见“更换砂带（参见插图A）”，页8）。

## 客户服务和应用咨询

### 中国大陆

电话：400 826 8484-3-2

### 制造商地址：

Robert Bosch Power Tools GmbH  
罗伯特·博世电动工具有限公司  
70538 Stuttgart / GERMANY  
70538 斯图加特 / 德国

关于服务地址和保修条件的链接请查看最后一页。

询问和订购备件时，务必提供机器铭牌上标示的10位数字物品代码。

## 处理废弃物

必须以符合环保的方式，回收再利用损坏的电动工具、充电电池、附件和废弃的包装材料。

不可以把电动工具和充电电池/蓄电池丢入一般的家庭垃圾中！



产品中有害物质的名称及含有的信息表

部件名称	有害物质									
	铅 (Pb)	汞 (Hg)	镉 (Cd)	六价铬 (Cr(VI))	多溴联苯 (PBBs)	多溴二苯醚 (PBDEs)	邻苯二甲酸二正丁酯 (DBP)	邻苯二甲酸二异丁酯 (DIBP)	邻苯二甲酸丁苄酯 (BBP)	邻苯二甲酸二(2-乙基)己酯 (DEHP)
外壳的金属部分	○	○	○	○	○	○	○	○	○	○
外壳的非金属部分	○	○	○	○	○	○	○	○	○	○
机械传动机构	○	○	○	○	○	○	○	○	○	○
电机组件	○	○	○	○	○	○	○	○	○	○
控制组件	○	○	○	○	○	○	○	○	○	○
附件	○	○	○	○	○	○	○	○	○	○
配件	○	○	○	○	○	○	○	○	○	○
连接件	○	○	○	○	○	○	○	○	○	○

产品中有害物质的名称及含有的信息表

部件名称	有害物质									
	铅 (Pb)	汞 (Hg)	镉 (Cd)	六价铬 (Cr(VI))	多溴联苯 (PBBs)	多溴二苯 醚 (PBDEs)	邻苯二 甲酸二 正丁酯 (DBP)	邻苯二 甲酸二 异丁酯 (DIBP)	邻苯二 甲酸丁 苄酯 (BBP)	邻苯二甲 酸二(2-乙 基)己酯 (DEHP)
电源线①	○	○	○	○	○	○	○	○	○	○
电池系统②	X	○	○	○	○	○	○	○	○	○

注1:

○: 表示该有害物质在该部件所有均质材料中的含量均不超出电器电子产品有害物质限制使用国家标准要求。

x: 表示该有害物质至少在该部件的某一均质材料中的含量超出电器电子产品有害物质限制使用国家标准要求。

注2:

以上未列出的部件，表明其有害物质含量均不超出电器电子产品有害物质限制使用国家标准要求。

①适用于采用电源线连接供电的产品。

②适用于采用充电电池供电的产品。

产品环保使用期限内的使用条件参见产品说明书。

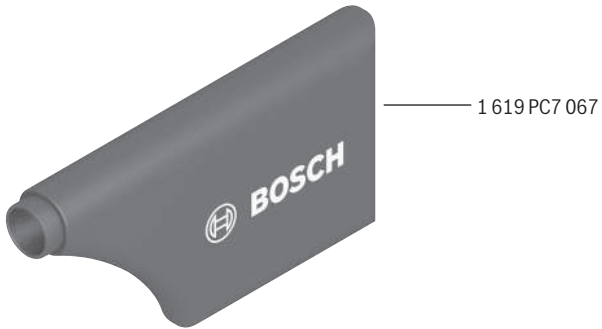
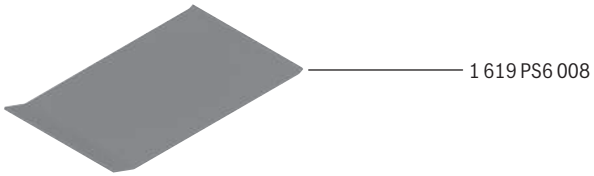
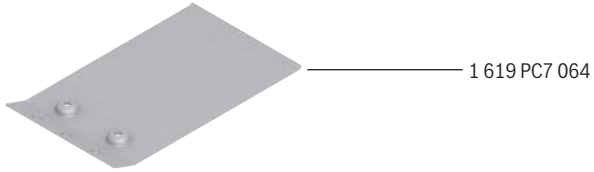

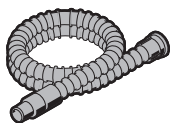

Ø 28 mm:  
2 608 000 772 (3.2 m)



GAS 18V-12 MC

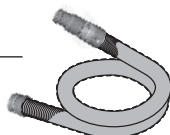

Ø 28 mm:  
2 608 000 885 (4 m)



GAS 12-40 MA

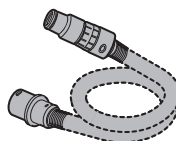

Ø 22 mm:  
2 608 000 567 (5 m)  
Ø 35 mm:  
2 608 000 565 (5 m)



GAS 35 M AFC



GAS 55 M AFC



Ø 22 mm:  
2 608 000 568 (5 m)  
Ø 35 mm:  
2 608 000 566 (5 m)

# Legal Information and Licenses

## 1- Open Source Components

### 1.1 - BSD-3-Clause

Copyright (c) 2015-2017, Infineon Technologies AG. All rights reserved.

Redistribution and use in source and binary forms, with or without modification, are permitted provided that the following conditions are met:

Redistributions of source code must retain the above copyright notice, this list of conditions and the following disclaimer.

Redistributions in binary form must reproduce the above copyright notice, this list of conditions and the following disclaimer in the documentation and/or other materials provided with the distribution.

Neither the name of the copyright holders nor the names of its contributors may be used to endorse or promote products derived from this software without specific prior written permission.

THIS SOFTWARE IS PROVIDED BY THE COPYRIGHT HOLDERS AND CONTRIBUTORS "AS IS" AND ANY EXPRESS OR IMPLIED WARRANTIES, INCLUDING, BUT NOT LIMITED TO, THE IMPLIED WARRANTIES OF MERCHANTABILITY AND FITNESS FOR A PARTICULAR PURPOSE ARE DISCLAIMED. IN NO EVENT SHALL THE COPYRIGHT HOLDER OR CONTRIBUTORS BE LIABLE FOR ANY DIRECT, INDIRECT, INCIDENTAL, SPECIAL, EXEMPLARY, OR CONSEQUENTIAL DAMAGES (INCLUDING, BUT NOT LIMITED TO, PROCUREMENT OF SUBSTITUTE GOODS OR SERVICES; LOSS OF USE, DATA, OR PROFITS; OR BUSINESS INTERRUPTION) HOWEVER CAUSED AND ON ANY THEORY OF LIABILITY, WHETHER IN CONTRACT, STRICT LIABILITY, OR TORT (INCLUDING NEGLIGENCE OR OTHERWISE) ARISING IN ANY WAY OUT OF THE USE OF THIS SOFTWARE, EVEN IF ADVISED OF THE POSSIBILITY OF SUCH DAMAGE.

### 1.2 - CMSIS\_5 - Apache-2.0

Copyright 2009-2020 Arm Limited. All rights reserved.

Licensed under the Apache License, Version 2.0 (the "License"); you may not use this file except in compliance with the License.

You may obtain a copy of the License at <http://www.apache.org/licenses/LICENSE-2.0>

Unless required by applicable law or agreed to in writing, software distributed under the License is distributed on an "AS IS" BASIS, WITHOUT WARRANTIES OR CONDITIONS OF ANY KIND, either express or implied. See the License for the specific language governing permissions and limitations under the License.

### 1.3 - Libfixmath - MIT

Copyright (c) 2011-2021 Flatmush <Flatmush@gmail.com>, Petteri Aimonen <Petteri.Aimonen@gmail.com>, & libfixmath AUTHORS libfixmath is Copyright (c) 2011-2021 Flatmush <Flatmush@gmail.com>, Petteri Aimonen <Petteri.Aimonen@gmail.com>, & libfixmath AUTHORS

Permission is hereby granted, free of charge, to any person obtaining a copy of this software and associated documentation files (the Software), to deal in the Software without restriction, including without limitation the rights to use, copy, modify, merge, publish, distribute, sublicense, and/or sell copies of the Software, and to permit persons to whom the Software is furnished to do so, subject to the following conditions:

The above copyright notice and this permission notice shall be included in all copies or substantial portions of the Software.

THE SOFTWARE IS PROVIDED AS IS, WITHOUT WARRANTY OF ANY KIND, EXPRESS OR IMPLIED, INCLUDING BUT NOT LIMITED TO THE WARRANTIES OF MERCHANTABILITY, FITNESS FOR A PARTICULAR PURPOSE AND NONINFRINGEMENT. IN NO EVENT SHALL THE AUTHORS OR COPYRIGHT HOLDERS BE LIABLE FOR ANY CLAIM, DAMAGES OR OTHER LIABILITY, WHETHER IN AN ACTION OF CONTRACT, TORT OR OTHERWISE, ARISING FROM, OUT OF OR IN CONNECTION WITH THE SOFTWARE OR THE USE OR OTHER DEALINGS IN THE SOFTWARE.

### 1.4 - MFixedPoint - MIT

Copyright 2018 Geoffrey Hunter

Permission is hereby granted, free of charge, to any person obtaining a copy of this software and associated documentation files (the "Software"), to deal in the Software without restriction, including without limitation the rights to use, copy, modify, merge, publish, distribute, sublicense, and/or sell copies of the Software, and to permit persons to whom the Software is furnished to do so, subject to the following conditions:

The above copyright notice and this permission notice shall be included in all copies or substantial portions of the Software.

THE SOFTWARE IS PROVIDED "AS IS", WITHOUT WARRANTY OF ANY KIND, EXPRESS OR IMPLIED, INCLUDING BUT NOT LIMITED TO THE WARRANTIES OF MERCHANTABILITY, FITNESS FOR A PARTICULAR PURPOSE AND NONINFRINGEMENT. IN NO EVENT SHALL THE AUTHORS OR COPYRIGHT HOLDERS BE LIABLE FOR ANY CLAIM, DAMAGES OR OTHER LIABILITY, WHETHER IN AN ACTION OF CONTRACT, TORT OR OTHERWISE, ARISING FROM, OUT OF OR IN CONNECTION WITH THE SOFTWARE OR THE USE OR OTHER DEALINGS IN THE SOFTWARE.

### 1.5 - GCE-Math - Apache-2.0

Copyright 2016-2023 Keith O'Hara

Permission is hereby granted, free of charge, to any person obtaining a copy of this software and associated documentation files (the Software), to deal in the Software without restriction, including without limitation the rights to use, copy, modify, merge, publish, distribute, sublicense, and/or sell copies of the Software, and to permit persons to whom the Software is furnished to do so, subject to the following conditions:

The above copyright notice and this permission notice shall be included in all copies or substantial portions of the Software.

THE SOFTWARE IS PROVIDED AS IS, WITHOUT WARRANTY OF ANY KIND, EXPRESS OR IMPLIED, INCLUDING BUT NOT LIMITED TO THE WARRANTIES OF MERCHANTABILITY, FITNESS FOR A PARTICULAR PURPOSE AND NONINFRINGEMENT. IN NO EVENT SHALL THE AUTHORS OR COPYRIGHT HOLDERS BE LIABLE FOR ANY CLAIM, DAMAGES OR OTHER LIABILITY, WHETHER IN AN ACTION OF CONTRACT, TORT OR OTHERWISE, ARISING FROM, OUT OF OR IN CONNECTION WITH THE SOFTWARE OR THE USE OR OTHER DEALINGS IN THE SOFTWARE.

### 1.7 - picolibc 1.8.8

(1) Copyright (c) 2001 Mike Barcroft <mike@FreeBSD.org> All rights reserved.

(2) Copyright 2002 Jeff Johnston <jjohnstn@redhat.com>

Redistribution and use in source and binary forms, with or without modification, are permitted provided that the following conditions are met:

1. Redistributions of source code must retain the above copyright notice, this list of conditions and the following disclaimer.
2. Redistributions in binary form must reproduce the above copyright notice, this list of conditions and the following disclaimer in the documentation and/or other materials provided with the distribution.

THIS SOFTWARE IS PROVIDED BY THE AUTHOR AND CONTRIBUTORS "AS IS" AND ANY EXPRESS OR IMPLIED WARRANTIES, INCLUDING, BUT NOT LIMITED TO, THE IMPLIED WARRANTIES OF MERCHANTABILITY AND FITNESS FOR A PARTICULAR PURPOSE ARE DISCLAIMED. IN NO EVENT SHALL THE AUTHOR OR CONTRIBUTORS BE LIABLE FOR ANY DIRECT, INDIRECT, INCIDENTAL, SPECIAL, EXEMPLARY, OR CONSEQUENTIAL DAMAGES (INCLUDING, BUT NOT LIMITED TO, PROCUREMENT OF SUBSTITUTE GOODS OR SERVICES; LOSS OF USE, DATA, OR PROFITS; OR BUSINESS INTERRUPTION) HOWEVER CAUSED AND ON ANY THEORY OF LIABILITY, WHETHER IN CONTRACT, STRICT LIABILITY, OR TORT (INCLUDING NEGLIGENCE OR OTHERWISE) ARISING IN ANY WAY OUT OF THE USE OF THIS

SOFTWARE, EVEN IF ADVISED OF THE POSSIBILITY OF SUCH DAMAGE.

(3) Copyright 2019, 2020, 2021, 2024 Keith Packard Stephen Street  
(4) Copyright 1997 Nick Clifton, Cygnus Solutions

Redistribution and use in source and binary forms, with or without modification, are permitted provided that the following conditions are met:

1. Redistributions of source code must retain the above copyright notice, this list of conditions and the following disclaimer.
2. Redistributions in binary form must reproduce the above copyright notice, this list of conditions and the following disclaimer in the documentation and/or other materials provided with the distribution.
3. Neither the name of the copyright holder nor the names of its contributors may be used to endorse or promote products derived from this software without specific prior written permission.

THIS SOFTWARE IS PROVIDED BY THE COPYRIGHT HOLDERS AND CONTRIBUTORS "AS IS" AND ANY EXPRESS OR IMPLIED WARRANTIES, INCLUDING, BUT NOT LIMITED TO, THE IMPLIED WARRANTIES OF MERCHANTABILITY AND FITNESS FOR A PARTICULAR PURPOSE ARE DISCLAIMED. IN NO EVENT SHALL THE COPYRIGHT HOLDER OR CONTRIBUTORS BE LIABLE FOR ANY DIRECT, INDIRECT, INCIDENTAL, SPECIAL, EXEMPLARY, OR CONSEQUENTIAL DAMAGES INCLUDING, BUT NOT LIMITED TO, PROCUREMENT OF SUBSTITUTE GOODS OR SERVICES; LOSS OF USE, DATA, OR PROFITS; OR BUSINESS INTERRUPTION) HOWEVER CAUSED AND ON ANY THEORY OF LIABILITY, WHETHER IN CONTRACT, STRICT LIABILITY, OR TORT (INCLUDING NEGLIGENCE OR OTHERWISE) ARISING IN ANY WAY OUT OF THE USE OF THIS SOFTWARE, EVEN IF ADVISED OF THE POSSIBILITY OF SUCH DAMAGE.

(5) Copyright 2024, Synopsis, Inc.

Redistribution and use in source and binary forms, with or without modification, are permitted provided that the following conditions are met:

- 1) Redistributions of source code must retain the above copyright notice, this list of conditions and the following disclaimer.
- 2) Redistributions in binary form must reproduce the above copyright notice, this list of conditions and the following disclaimer in the documentation and/or other materials provided with the distribution.
- 3) Neither the name of the Synopsis, Inc., nor the names of its contributors may be used to endorse or promote products derived from this software without specific prior written permission.

THIS SOFTWARE IS PROVIDED BY THE COPYRIGHT HOLDERS AND CONTRIBUTORS "AS IS" AND ANY EXPRESS OR IMPLIED WARRANTIES, INCLUDING, BUT NOT LIMITED TO, THE IMPLIED WARRANTIES OF MERCHANTABILITY AND FITNESS FOR A PARTICULAR PURPOSE ARE DISCLAIMED. IN NO EVENT SHALL THE COPYRIGHT HOLDER OR CONTRIBUTORS BE LIABLE FOR ANY DIRECT, INDIRECT, INCIDENTAL, SPECIAL, EXEMPLARY, OR CONSEQUENTIAL DAMAGES (INCLUDING, BUT NOT LIMITED TO, PROCUREMENT OF SUBSTITUTE GOODS OR SERVICES; LOSS OF USE, DATA, OR PROFITS; OR BUSINESS INTERRUPTION) HOWEVER CAUSED AND ON ANY THEORY OF LIABILITY, WHETHER IN CONTRACT, STRICT LIABILITY, OR TORT (INCLUDING NEGLIGENCE OR OTHERWISE) ARISING IN ANY WAY OUT OF THE USE OF THIS SOFTWARE, EVEN IF ADVISED OF THE POSSIBILITY OF SUCH DAMAGE.

(6) Copyright (c) 1983, 1993 The Regents of the University of California. All rights reserved.

Redistribution and use in source and binary forms, with or without modification, are permitted provided that the following conditions are met:

1. Redistributions of source code must retain the above copyright notice, this list of conditions and the following disclaimer.
2. Redistributions in binary form must reproduce the above copyright notice, this list of conditions and the following disclaimer in the documentation and/or other materials provided with the distribution.
3. Neither the name of the University nor the names of its contributors

may be used to endorse or promote products derived from this software without specific prior written permission.

THIS SOFTWARE IS PROVIDED BY THE REGENTS AND CONTRIBUTORS "AS IS" AND ANY EXPRESS OR IMPLIED WARRANTIES, INCLUDING, BUT NOT LIMITED TO, THE IMPLIED WARRANTIES OF MERCHANTABILITY AND FITNESS FOR A PARTICULAR PURPOSE ARE DISCLAIMED. IN NO EVENT SHALL THE REGENTS OR CONTRIBUTORS BE LIABLE FOR ANY DIRECT, INDIRECT, INCIDENTAL, SPECIAL, EXEMPLARY, OR CONSEQUENTIAL DAMAGES (INCLUDING, BUT NOT LIMITED TO, PROCUREMENT OF SUBSTITUTE GOODS OR SERVICES; LOSS OF USE, DATA, OR PROFITS; OR BUSINESS INTERRUPTION) HOWEVER CAUSED AND ON ANY THEORY OF LIABILITY, WHETHER IN CONTRACT, STRICT LIABILITY, OR TORT (INCLUDING NEGLIGENCE OR OTHERWISE) ARISING IN ANY WAY OUT OF THE USE OF THIS SOFTWARE, EVEN IF ADVISED OF THE POSSIBILITY OF SUCH DAMAGE.

(7) Copyright 2009-2015 ARM Ltd

Redistribution and use in source and binary forms, with or without modification, are permitted provided that the following conditions are met:

1. Redistributions of source code must retain the above copyright notice, this list of conditions and the following disclaimer.
2. Redistributions in binary form must reproduce the above copyright notice, this list of conditions and the following disclaimer in the documentation and/or other materials provided with the distribution.
3. The name of the company may not be used to endorse or promote products derived from this software without specific prior written permission.

THIS SOFTWARE IS PROVIDED BY ARM LTD "AS IS" AND ANY EXPRESS OR IMPLIED WARRANTIES, INCLUDING, BUT NOT LIMITED TO, THE IMPLIED WARRANTIES OF MERCHANTABILITY AND FITNESS FOR A PARTICULAR PURPOSE ARE DISCLAIMED. IN NO EVENT SHALL ARM LTD BE LIABLE FOR ANY DIRECT, INDIRECT, INCIDENTAL, SPECIAL, EXEMPLARY, OR CONSEQUENTIAL DAMAGES (INCLUDING, BUT NOT LIMITED TO, PROCUREMENT OF SUBSTITUTE GOODS OR SERVICES; LOSS OF USE, DATA, OR PROFITS; OR BUSINESS INTERRUPTION) HOWEVER CAUSED AND ON ANY THEORY OF LIABILITY, WHETHER IN CONTRACT, STRICT LIABILITY, OR TORT (INCLUDING NEGLIGENCE OR OTHERWISE) ARISING IN ANY WAY OUT OF THE USE OF THIS SOFTWARE, EVEN IF ADVISED OF THE POSSIBILITY OF SUCH DAMAGE.

(8) Copyright 2009-2015 Linaro Limited

Redistribution and use in source and binary forms, with or without modification, are permitted provided that the following conditions are met:

Redistributions of source code must retain the above copyright notice, this list of conditions and the following disclaimer. Redistributions in binary form must reproduce the above copyright notice, this list of conditions and the following disclaimer in the documentation and/or other materials provided with the distribution. Neither the name of Linaro Limited nor the names of its contributors may be used to endorse or promote products derived from this software without specific prior written permission.

THIS SOFTWARE IS PROVIDED BY THE COPYRIGHT HOLDERS AND CONTRIBUTORS AS IS AND ANY EXPRESS OR IMPLIED WARRANTIES, INCLUDING, BUT NOT LIMITED TO, THE IMPLIED WARRANTIES OF MERCHANTABILITY AND FITNESS FOR A PARTICULAR PURPOSE ARE DISCLAIMED. IN NO EVENT SHALL THE COPYRIGHT HOLDER OR CONTRIBUTORS BE LIABLE FOR ANY DIRECT, INDIRECT, INCIDENTAL, SPECIAL, EXEMPLARY, OR CONSEQUENTIAL DAMAGES (INCLUDING, BUT NOT LIMITED TO, PROCUREMENT OF SUBSTITUTE GOODS OR SERVICES; LOSS OF USE, DATA, OR PROFITS; OR BUSINESS INTERRUPTION) HOWEVER CAUSED AND ON ANY THEORY OF LIABILITY, WHETHER IN CONTRACT, STRICT LIABILITY, OR TORT (INCLUDING NEGLIGENCE OR OTHERWISE) ARISING IN ANY WAY OUT OF THE USE OF THIS SOFTWARE, EVEN IF ADVISED OF THE POSSIBILITY OF SUCH DAMAGE.

(9) Copyright 1994 Cygnus Support

Redistribution and use in source and binary forms are permitted provided that the above copyright notice and this paragraph are duplicated in all such forms and that any documentation, and/or other materials related to such distribution and use acknowledge that the software was developed at Cygnus Support, Inc. Cygnus Support, Inc. may not be used to endorse or promote products derived from this software without specific prior written permission.

THIS SOFTWARE IS PROVIDED "AS IS" AND WITHOUT ANY EXPRESS OR IMPLIED WARRANTIES, INCLUDING, WITHOUT LIMITATION, THE IMPLIED WARRANTIES OF MERCHANTABILITY AND FITNESS FOR A PARTICULAR PURPOSE.

## 2. Common Licenses

### 2.1 Apache License 2.0 (Apache-2.0)

Apache-2.0

Apache License

Version 2.0, January 2004

<http://www.apache.org/licenses/>

TERMS AND CONDITIONS FOR USE, REPRODUCTION, AND DISTRIBUTION

#### 1. Definitions.

"License" shall mean the terms and conditions for use, reproduction, and distribution as defined by Sections 1 through 9 of this document.

"Licensor" shall mean the copyright owner or entity authorized by the copyright owner that is granting the License.

"Legal Entity" shall mean the union of the acting entity and all other entities that control, are controlled by, or are under common control with that entity. For the purposes of this definition, "control" means (i) the power, direct or indirect, to cause the direction or management of such entity, whether by contract or otherwise, or (ii) ownership of fifty percent (50%) or more of the outstanding shares, or (iii) beneficial ownership of such entity.

"You" (or "Your") shall mean an individual or Legal Entity exercising permissions granted by this License.

"Source" form shall mean the preferred form for making modifications, including but not limited to software source code, documentation source, and configuration files.

"Object" form shall mean any form resulting from mechanical transformation or translation of a Source form, including but not limited to compiled object code, generated documentation, and conversions to other media types.

"Work" shall mean the work of authorship, whether in Source or Object form, made available under the License, as indicated by a copyright notice that is included in or attached to the work (an example is provided in the Appendix below).

"Derivative Works" shall mean any work, whether in Source or Object form, that is based on (or derived from) the Work and for which the editorial revisions, annotations, elaborations, or other modifications represent, as a whole, an original work of authorship. For the purposes of this License, Derivative Works shall not include works that remain separable from, or merely link (or bind by name) to the interfaces of, the Work and Derivative Works thereof.

"Contribution" shall mean any work of authorship, including the original version of the Work and any modifications or additions to that Work or Derivative Works thereof, that is intentionally submitted to Licensor for inclusion in the Work by the copyright owner or by an individual or Legal Entity authorized to submit on behalf of the copyright owner. For the purposes of this definition, "submitted" means any form of electronic, verbal, or written communication sent to the Licensor or its representatives, including but not limited to communication on electronic mailing lists, source code control systems, and issue tracking systems that are managed by, or on behalf of, the Licensor for the purpose of discussing and improving the Work, but excluding communication that is conspicuously marked or otherwise designated in writing by the copyright owner as "Not a Contribution."

"Contributor" shall mean Licensor and any individual or Legal Entity on behalf of whom a Contribution has been received by Licensor and subsequently incorporated within the Work.

2. Grant of Copyright License. Subject to the terms and conditions of this License, each Contributor hereby grants to You a perpetual, worldwide, non-exclusive, no-charge, royalty-free, irrevocable copyright license to reproduce, prepare Derivative Works of, publicly display, publicly perform, sublicense, and distribute the Work and such Derivative Works in Source or Object form.

3. Grant of Patent License. Subject to the terms and conditions of this License, each Contributor hereby grants to You a perpetual, worldwide, non-exclusive, no-charge, royalty-free, irrevocable (except as stated in this section) patent license to make, have made, use, offer to sell, sell, import, and otherwise transfer the Work, where such license applies only to those patent claims licensable by such Contributor that are necessarily infringed by their Contribution(s) alone or by combination of their Contribution(s) with the Work to which such Contribution(s) was submitted. If You institute patent litigation against any entity (including a cross-claim or counterclaim in a lawsuit) alleging that the Work or a Contribution incorporated within the Work constitutes direct or contributory patent infringement, then any patent licenses granted to You under this License for that Work shall terminate as of the date such litigation is filed.

4. Redistribution. You may reproduce and distribute copies of the Work or Derivative Works thereof in any medium, with or without modifications, and in Source or Object form, provided that You meet the following conditions:

(a) You must give any other recipients of the Work or Derivative Works a copy of this License; and

(b) You must cause any modified files to carry prominent notices stating that You changed the files; and

(c) You must retain, in the Source form of any Derivative Works that You distribute, all copyright, patent, trademark, and attribution notices from the Source form of the Work, excluding those notices that do not pertain to any part of the Derivative Works; and

(d) If the Work includes a "NOTICE" text file as part of its distribution, then any Derivative Works that You distribute must include a readable copy of the attribution notices contained within such NOTICE file, excluding those notices that do not pertain to any part of the Derivative Works, in at least one of the following places: within a NOTICE text file distributed as part of the Derivative Works; within the Source form or documentation, if provided along with the Derivative Works; or, within a display generated by the Derivative Works, if and wherever such third-party notices normally appear. The contents of the NOTICE file are for informational purposes only and do not modify the License. You may add Your own attribution notices within Derivative Works that You distribute, alongside or as an addendum to the NOTICE text from the Work, provided that such additional attribution notices cannot be construed as modifying the License.

You may add Your own copyright statement to Your modifications and may provide additional or different license terms and conditions for use, reproduction, or distribution of Your modifications, or for any such Derivative Works as a whole, provided Your use, reproduction, and distribution of the Work otherwise complies with the conditions stated in this License.

5. Submission of Contributions. Unless You explicitly state otherwise, any Contribution intentionally submitted for inclusion in the Work by You to the Licensor shall be under the terms and conditions of this License, without any additional terms or conditions. Notwithstanding the above, nothing herein shall supersede or modify the terms of any separate license agreement you may have executed with Licensor regarding such Contributions.

6. Trademarks. This License does not grant permission to use the trade names, trademarks, service marks, or product names of the Licensor, except as required for reasonable and customary use in describing the origin of the Work and reproducing the content of the NOTICE file.

7. Disclaimer of Warranty. Unless required by applicable law or agreed to in writing, Licensor provides the Work (and each Contributor

provides its Contributions) on an "AS IS" BASIS, WITHOUT WARRANTIES OR CONDITIONS OF ANY KIND, either express or implied, including, without limitation, any warranties or conditions of TITLE, NON-INFRINGEMENT, MERCHANTABILITY, or FITNESS FOR A PARTICULAR PURPOSE. You are solely responsible for determining the appropriateness of using or redistributing the Work and assume any risks associated with Your exercise of permissions under this License.

8. Limitation of Liability. In no event and under no legal theory, whether in tort (including negligence), contract, or otherwise, unless required by applicable law (such as deliberate and grossly negligent acts) or agreed to in writing, shall any Contributor be liable to You for damages, including any direct, indirect, special, incidental, or consequential damages of any character arising as a result of this License or out of the use or inability to use the Work (including but not limited to damages for loss of goodwill, work stoppage, computer failure or malfunction, or any and all other commercial damages or losses), even if such Contributor has been advised of the possibility of such damages.

9. Accepting Warranty or Additional Liability. While redistributing the Work or Derivative Works thereof, You may choose to offer, and charge a fee for, acceptance of support, warranty, indemnity, or other liability obligations and/or rights consistent with this License. However, in accepting such obligations, You may act only on Your own behalf and on Your sole responsibility, not on behalf of any other Contributor, and only if You agree to indemnify, defend, and hold each Contributor harmless for any liability incurred by, or claims asserted against, such Contributor by reason of your accepting any such warranty or additional liability.

END OF TERMS AND CONDITIONS

### **3- WARRANTY DISCLAIMER**

This product contains Open Source Software components which underlie Open Source Software Licenses. Please note that Open Source Licenses contain disclaimer clauses. The text of the Open Source Licenses that apply are included in this manual under "Legal Information and Licenses".



Servicekontakte  
Service Contacts  
Contacts de Service  
Contactos de Servicio



<https://www.bosch-pt.com/serviceaddresses>

Garantiebedingungen  
Guarantee Conditions  
Conditions de Garantie  
Condiciones de Garantía



<https://www.bosch-pt.com/guarantee/202601>