



# BOSCH



# Price List 2023

[www.bosch-professional.com](http://www.bosch-professional.com)

**AUG Edition**



# Contents

Description	Page
<b>Accessories</b>	
<b>Metal Drilling: The Complete Range Hand Held Applications</b>	<b>3</b>
<b>HSS-G Metal Drill Bit</b>	<b>4 - 5</b>
<b>HSS-G Set, 1/4" Hex Shank HSS-G Metal Drill Bit, HSS-CO Cobalt 135° Metal Drill Bit</b>	<b>6</b>
<b>Screwdriver Bit, Bulk Screwdriver Bit</b>	<b>7</b>
<b>Drill In All Materials: Totally Precise</b>	<b>8</b>
<b>Straight Shank Drill Bit- Masonry (CYL-2), Silver Percussion (CYL-3), Hex-9 Multi Construction Drill Bit, Hex-9 Hard Ceramic Drill Bit, Core Drill Bit, Multi Purpose (CYL-4), Ceramic Expert Drill Bit (CYL-9 Ceramic)</b>	<b>9</b>
<b>From the SDS inventor: High Robustness In Concrete</b>	<b>10</b>
<b>SDS Plus Drill Bit- SDS Plus-1</b>	<b>11</b>
<b>SDS Plus Drill Bit- SDS Plus-5 (New Shrink Sleeve Packaging), SDS Plus-5X</b>	<b>12-13</b>
<b>SDS Plus Core Cutter, SDS Max Core Cutter, SDS Max-4</b>	<b>14</b>
<b>SDS Max Hammer Drill Bit- SDS Max- 7, SDS Max- 8X</b>	<b>15</b>
<b>SDS Plus Chisel, Hexagonal Chisel</b>	<b>16</b>
<b>Perfect For Diamond Cutting, Grinding And Drilling</b>	<b>17-18</b>
<b>Standard for Diamond Cutting Disc , Diamond Drill Bits/ Holesaw</b>	<b>19-21</b>
<b>Complete Range Of Circular Saw Blades: Incomparable Precision Of Cuts</b>	<b>22</b>
<b>Circular Saw Accessories</b>	<b>23</b>
<b>The Complete Hole Saw Range: For Maximum Performance In All Applications</b>	<b>24</b>
<b>Bi-Metal Holesaw</b>	<b>25</b>
<b>Progressor Holesaw</b>	<b>26-27</b>
<b>TCT Holesaw</b>	<b>28</b>
<b>Jigsaw Blades: Unrivalled Capability In All Kinds Of Materials</b>	<b>29</b>
<b>Cutting &amp; Sawing</b>	<b>30</b>
<b>Jigsaw Accessories</b>	<b>31-33</b>
<b>Reciprocating Saw Blades: Longest Lifetime In Toughest Materials</b>	<b>34</b>
<b>Sabre Saw Blade: Carbide Series</b>	<b>35-36</b>
<b>Sabre Saw Blade &amp; Reciprocating Saw Blade</b>	<b>37-39</b>
<b>Cordless Multi- Cutter Accessories</b>	<b>40-41</b>
<b>X-lock The Ultimate Changing System For Grinders: Perfect For Cutting, Grinding And Brushing</b>	<b>42</b>
<b>Bonded &amp; Coated Abrasive. Accessories for Angle Grinder &amp; Cut Off Machine</b>	<b>43</b>
<b>Bonded &amp; Coated Abrasive. Accessories for Angle Grinder &amp; Straight Grinders</b>	<b>44</b>
<b>Coated Velcro Disc</b>	<b>45</b>
<b>Hand Sanding Sheets</b>	<b>46</b>
<b>Foam &amp; Sponge Abrasive (hand sanding), Non Woven Abrasive for Metal &amp; Inox</b>	<b>47</b>
<b>Multi Sander Accessories, Bench Grinder Accessories, Belt Sander Accessories</b>	<b>48</b>
<b>TCT Annular Cutter, Multi Sander Accessories, Key Chuck &amp; Keyless Chuck, Chuck Key</b>	<b>49</b>
<b>Straight Grinder, Trimmer and Router Accessories, Angle Grinder Accessories, Polisher &amp; Angle Grinder Accessories</b>	<b>50</b>
<b>Sanding &amp; Polishing for Drill, De-rusting Accessories for Drill, Shaping Accessories for Drill</b>	<b>51</b>
<b>Router Bit (Carbide- Tipped) - 1/4" Shank</b>	<b>52</b>
<b>Planer Accessories, Other Tools, Foam Rubber Cutter Accessories</b>	<b>53</b>
<b>Shear Accessories (Metal), Nibbler Accessories (Metal), Vacuum Cleaner Accessories</b>	<b>54</b>
<b>Hot Air Gun Accessories</b>	<b>55</b>
<b>Service</b>	
<b>Rotary Hammer, Demolition Hammer, Grease for Hammer, Oil for Hammer</b>	<b>56</b>
<b>Bosch Range Spare Parts</b>	<b>57</b>
<b>Spare Parts Price List</b>	<b>58-70</b>
<b>Warranty &amp; Authorised Service Centres</b>	<b>71</b>

Metal Drilling:

# THE COMPLETE RANGE FOR HAND HELD APPLICATIONS

The best your tool can get. Bosch Professional Accessories.



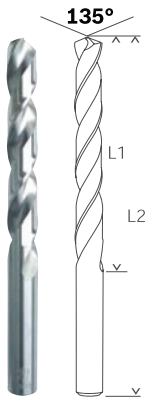

**135° split point**



**Precise drilling**



**German industrial norm DIN 338**

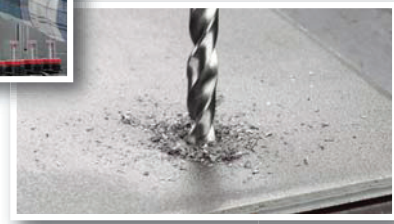

## HSS-G Metal Drill Bit

Part Number	Diameter (mm)	Quantity per Pack (in piece)	Working length L1 (mm)	Total length L2 (mm)	List Price (RM)
<b>HSS-G Metal Drill Bit</b>					
2 608 595 049	1.0	10	12	34	25.10
2 608 585 467	1.1	10	14	36	25.10 *
468	1.2	10	16	38	25.10 *
469	1.3	10	16	38	25.10
470	1.4	10	18	40	25.10 *
2 608 595 050	1.5	10	18	40	25.10
2 608 585 471	1.6	10	20	43	25.10 *
472	1.7	10	20	43	25.10
473	1.8	10	22	46	25.10
474	1.9	10	22	46	25.10 *
2 608 595 051	2.0	10	24	49	28.80
2 608 585 475	2.1	10	24	49	28.80 *
2 608 595 052	2.2	10	27	53	28.80
2 608 585 476	2.3	10	27	53	28.80 *
477	2.4	10	30	57	28.80
2 608 595 053	2.5	10	30	57	28.80
2 608 585 478	2.6	10	30	57	28.80
479	2.7	10	33	61	28.80
2 608 595 054	2.8	10	33	61	28.80
2 608 585 480	2.9	10	33	61	28.80
2 608 595 055	3.0	10	33	61	28.80
2 608 585 481	3.1	10	36	65	42.50
2 608 595 056	3.2	10	36	65	42.50
057	3.3	10	36	65	42.50
2 608 585 482	3.4	10	39	70	42.50
2 608 595 058	3.5	10	39	70	42.50
332	3.6	10	39	70	42.50
2 608 585 483	3.7	10	39	70	42.50 *
484	3.8	10	43	75	42.50
485	3.9	10	43	75	42.50
2 608 595 059	4.0	10	43	75	42.50
2 608 585 486	4.1	10	43	75	31.60
2 608 595 060	4.2	10	43	75	46.50
2 608 585 487	4.3	10	47	80	46.50
2 608 595 333	4.4	10	47	80	46.50
061	4.5	10	47	80	46.50
2 608 585 488	4.6	10	47	80	46.50 *
489	4.7	10	47	80	46.50 *
2 608 595 334	4.8	10	52	86	46.50
2 608 585 490	4.9	10	52	86	46.50
2 608 595 062	5.0	10	52	86	46.50
2 608 585 491	5.1	10	52	86	61.00
2 608 595 063	5.2	10	52	86	61.00
2 608 585 492	5.3	10	52	86	61.00
493	5.4	10	57	93	61.00
2 608 595 064	5.5	10	57	93	61.00
2 608 585 494	5.6	10	57	93	61.00
495	5.7	10	57	93	61.00 *
2 608 595 065	5.8	10	57	93	61.00
2 608 585 496	5.9	10	57	93	61.00 *
2 608 595 066	6.0	10	57	93	61.00
2 608 585 497	6.1	10	63	101	74.60 *
2 608 595 067	6.2	10	63	101	74.60
2 608 585 498	6.3	10	63	101	74.60
2 608 595 335	6.4	10	63	101	74.60
068	6.5	10	63	101	74.60
2 608 585 499	6.6	10	63	101	74.60
2 608 595 336	6.7	10	63	101	74.60
069	6.8	10	69	109	75.80
2 608 585 500	6.9	10	69	109	76.00 *

(1.0 - 7.9mm) 10 pcs / pkt

(8.0 - 13.0mm) 5 pcs / pkt

(14.0 - 16.0mm) 4 pcs / pkt

**Note:** \*Items marked are based on Indent Basis.

Valid in West Malaysia and while stocks last only.

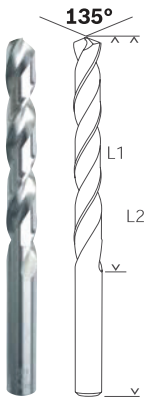

**135° split point**



**Precise drilling**



**German industrial norm DIN 338**



## HSS-G Metal Drill Bit

Part Number	Diameter (mm)	Quantity per Pack (in piece)	Working length L1 (mm)	Total length L2 (mm)	List Price (RM)
2 608 595 070	7.0	10	69	109	75.80
2 608 585 501	7.1	10	69	109	76.00*
2 608 595 337	7.2	10	69	109	76.00
2 608 585 502	7.3	10	69	109	102.50
503	7.4	10	69	109	102.50*
2 608 595 071	7.5	10	69	109	102.50
2 608 585 504	7.6	10	75	117	124.00*
505	7.7	10	75	117	124.00*
506	7.8	10	75	117	124.00
507	7.9	10	75	117	124.00*
2 608 595 072	8.0	5	75	117	81.00
2 608 585 508	8.1	5	75	117	81.00
509	8.2	5	75	117	81.00
510	8.3	5	75	117	81.00*
511	8.4	5	75	117	81.00*
2 608 595 073	8.5	5	75	117	81.00
2 608 585 512	8.6	5	81	125	81.00*
513	8.7	5	81	125	81.00
2 608 595 074	8.8	5	81	125	81.00
2 608 585 514	8.9	5	81	125	81.00*
2 608 595 075	9.0	5	81	125	81.00
2 608 585 515	9.1	5	81	125	92.00*
516	9.2	5	81	125	92.00*
517	9.3	5	81	125	92.00*
518	9.4	5	81	125	92.00*
2 608 595 076	9.5	5	81	125	92.00
2 608 585 519	9.6	5	87	133	92.00
520	9.7	5	87	133	92.00*
2 608 595 338	9.8	5	87	133	92.50
2 608 585 521	9.9	5	87	133	92.00*
2 608 595 077	10.0	5	87	133	92.00
2 608 585 522	10.1	5	87	133	105.50*
523	10.2	5	87	133	105.50
524	10.3	5	87	133	105.50*
525	10.4	5	87	133	105.50*
2 608 595 078	10.5	5	87	133	105.50
2 608 585 526	10.6	5	87	133	105.50*
527	10.7	5	94	142	105.50*
528	10.8	5	94	142	105.50*
529	10.9	5	94	142	105.50*
2 608 595 079	11.0	5	94	142	105.50
2 608 585 530	11.1	5	94	142	118.50
531	11.2	5	94	142	118.50*
532	11.3	5	94	142	118.50*
533	11.4	5	94	142	118.50*
2 608 595 080	11.5	5	94	142	118.50
2 608 585 534	11.6	5	94	142	122.00*
535	11.7	5	94	142	122.00*
536	11.8	5	101	151	122.00*
537	11.9	5	101	151	122.00*
2 608 595 081	12.0	5	101	151	122.00
2 608 585 538	12.1	5	101	151	122.00*
539	12.2	5	101	151	122.00*
540	12.3	5	101	151	122.00*
541	12.4	5	101	151	122.00*
2 608 595 082	12.5	5	101	151	122.00
2 608 585 542	12.6	5	101	151	163.00*
543	12.7	5	101	151	163.00
544	12.8	5	101	151	163.00*
545	12.9	5	101	151	163.00*
2 608 595 083	13.0	5	101	151	163.00
2 608 585 593	14.0	4	108	160	286.50
594	15.0	4	114	169	300.50
595	16.0	4	120	178	335.00

**Note:** \*Items marked are based on Indent Basis.

Valid in West Malaysia and while stocks last only.



D-point

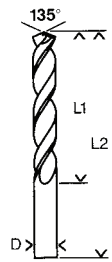

DIN 338, cobalt content 5%. Right-hand cutting Type N, drill bit tip 135°, split point manufactured to DIN 1412 C, diameter tolerance h 8. Suitable for drilling - only with cooling - in alloyed and unalloyed steel up to a tensile strength of 1000 N/mm<sup>2</sup>, stainless steel V2A/V4A, cast iron.



1



2



3



## HSS-G Set

Part Number	Diameter (mm)	Quantity per Pack (in piece)	Working length L1 (mm)	Total length L2 (mm)	List Price (RM)
<b>HSS-G Set</b>					
1 2 607 019 114	2, 3, 4, 5 & 6	HSS-G 5 pcs Set			26.30
115	1 to 10 (by 1.0 mm)	HSS-G 10 pcs Set			90.00
116	1 to 10 (by 0.5 mm)	HSS-G 19 pcs Set			180.30

### Hex Shank HSS-G Metal Drill Bit

2 608 577 045	2	1	24	60	9.20
048	3	1	33	72	11.55
052	4	1	43	83	10.95
056	5	1	52	91	14.45
058	6	1	57	98	17.30
2 061	8	1	75	117	25.40
146	2/3/4/5/6/7/8/10	8			201.00

### HSS-CO Cobalt 135° Metal Drill Bit Suitable for V2A & V4A (INOX) Stainless Steel or Pipe

3 2 608 585 872	1.0	10	12	34	33.30
873	1.5	10	18	40	33.30
874	2.0	10	24	49	38.00
875	2.5	10	30	57	38.00
876	3.0	10	33	61	38.00
877	3.2	10	36	65	56.30
878	3.3	10	36	65	56.30
879	3.5	10	39	70	56.30
880	4.0	10	43	75	56.30
881	4.1	10	43	75	62.00
882	4.2	10	43	75	62.00
883	4.5	10	47	80	62.00
884	4.8	10	52	86	77.50 *
885	5.0	10	52	86	77.50
886	5.1	10	52	86	100.50
887	5.2	10	52	86	100.50 *
888	5.5	10	57	93	100.50
889	6.0	10	57	93	100.50
890	6.5	10	63	101	124.00
891	6.8	10	69	109	144.50
892	7.0	10	69	109	144.50
893	7.5	10	69	109	170.00
894	8.0	5	75	117	103.50
895	8.5	5	75	117	135.50
896	9.0	5	81	125	135.50
897	9.5	5	81	125	153.60
898	10.0	5	87	133	154.00
899	10.2	5	87	133	175.50 *
900	10.5	5	87	133	175.50
901	11.0	5	94	142	186.00
902	11.5	5	94	142	222.50
903	12.0	5	101	151	232.00
904	12.5	5	101	151	250.00 *
905	13.0	5	101	151	269.50

(1.0 - 7.5mm) 10 pcs / pkt (8.0 - 13.0mm) 5 pcs / pkt

**Note:** \*Items marked are based on Indent Basis.

Valid in West Malaysia and while stocks last only.



1



2



3

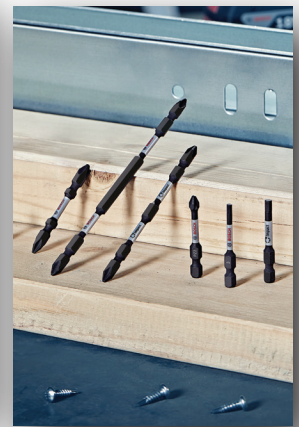

## Bulk Screwdriver Bit (100pcs / pkt)

<b>2 608 522 372</b>	Double ended screw driver bit 65mm Golden (100pcs)	<b>321.00</b>
<b>373</b>	Double ended screw driver bit 110mm Golden (100pcs)	<b>527.50</b>

## Screwdriver Bit

Part Number	Description	Quantity per Pack (in piece)	List Price (RM)
<b>2 608 522 255</b>	Screwdriver Bit (PH2-150) (5pcs) Gold		<b>65.40</b>
<b>265</b>	Screwdriver Bit (PH2-SL6-65) (10pcs) Grey		<b>39.60</b>
<b>266</b>	Screwdriver Bit (PH2-SL6-110) (10pcs) Grey		<b>56.30</b>
<b>1</b>	<b>405</b> Impact Bit PH2 X 65mm (10pcs Pack)		<b>100.50</b>
	<b>406</b> Impact Bit PH2 X 110mm (10pcs Pack)		<b>146.00</b>
	<b>407</b> Impact Bit PH2 X 150mm (5pcs Pack)		<b>112.00</b>
<b>2</b>	<b>491</b> Impact Control Power Bit (3pcs Set)		<b>17.30</b>
<b>2 608 521 041</b>	Philips #2 magnetised, Gold (10pcs x 45 mm)		<b>47.70</b>
	<b>042</b> Philips #2 magnetised, Gold (10pcs x 65 mm)		<b>50.00</b>
	<b>043</b> Philips #2 magnetised, Gold (10pcs x 110 mm)		<b>66.00</b>
<b>3</b>	<b>2 607 019 454</b> 10 pieces Screwdriver Bit Set		<b>59.50</b>

**Note:** \*Items marked are based on Indent Basis.  
Valid in West Malaysia and while stocks last only.



Drill in all materials:

**TOTALLY  
PRECISE**

The best your tool can get. Bosch Professional Accessories.







## Straight Shank Drill Bit

Part Number	<b>EXPERT</b>	Description	List Price (RM)
<b>Masonry (CYL-2)</b>			
1	2 608 578 114	Masonry Drill Bit (3 mm x 30/60 mm)	3.20
	115	Masonry Drill Bit (4 mm x 40/75 mm)	3.75
	116	Masonry Drill Bit (5 mm x 50/85 mm)	4.35
	117	Masonry Drill Bit (5.5 mm x 50/85 mm)	4.35
	118	Masonry Drill Bit (6 mm x 60/100 mm)	4.35
	119	Masonry Drill Bit (6.5 mm x 60/100 mm)	4.35
	120	Masonry Drill Bit (8 mm x 80/120 mm)	4.85
	159	Masonry Drill Bit (9 mm x 80/120 mm)	5.25
	121	Masonry Drill Bit (10 mm x 80/120 mm)	7.55
	122	Masonry Drill Bit (12 mm x 90/150 mm)	10.75
	123	Masonry Drill Bit (14 mm x 90/150 mm)	13.10
	160	Masonry Drill Bit (16 mm x 90/150 mm)	15.10
	124	Masonry Drill Bit Set (6/8/10)	15.60
	155	Masonry Drill Bit Set (4/5/6/8/10)	21.00
	156	Masonry Drill Bit Set (3/4/5/6/7/8/9/10)	23.60
<b>Silver Percussion (CYL-3)</b>			
2	2 608 680 725	Concrete Drill Bit 3 pcs Set (5, 6 & 8mm)	23.60
	726	Concrete Drill Bit 5 pcs Set (4, 5, 6, 8 & 10mm)	40.60
<b>Multi Purpose (CYL-4)</b>			
	2 608 680 798	Multi Purpose Drill Bit 5 pcs Set (4, 5, 6, 8 & 10 mm)	48.00
	799	Multi Purpose Drill Bit 8 pcs Set (3, 4, 5, 5.5, 6, 7, 8 & 10 mm)	73.30
<b>Hex-9 Multi Construction Drill Bit (Replacement for CYL-4)</b>			
3	2 607 002 773	2 608 900 569 HEX-9 MultiConstruction Drill Bit, 3x45x90	9.60
	774	570 HEX-9 MultiConstruction Drill Bit, 4x45x90	9.70
	775	571 HEX-9 MultiConstruction Drill Bit, 5x50x100	10.30
	776	572 HEX-9 MultiConstruction Drill Bit, 5.5x60x100	10.65
	2 608 579 836	573 HEX-9 MultiConstruction Drill Bit, 5.5x90x150	10.65
	2 607 002 777	574 HEX-9 MultiConstruction Drill Bit, 6x60x100	11.55
	2 608 579 837	575 HEX-9 MultiConstruction Drill Bit, 6x90x150	11.55
	2 607 002 778	579 HEX-9 MultiConstruction Drill Bit, 7x50x100	12.10
	2 608 579 839	580 HEX-9 MultiConstruction Drill Bit, 7x90x150	12.10
	2 607 002 779	581 HEX-9 MultiConstruction Drill Bit, 8x50x100	12.70
	780	582 HEX-9 MultiConstruction Drill Bit, 10x90x150	15.20
	2 608 579 840	583 HEX-9 MultiConstruction Drill Bit, 12x90x150	24.80
	2 608 589 530	585 HEX-9 MultiConstruction Drill Bit, 5pc set 4/5/6/8	51.20
<b>Ceramic Expert Drill Bit (CYL-9 Ceramic)</b>			
4	2 608 587 160	Ceramic 5.5 mm x 70 mm	23.00
	162	Ceramic 6.5 mm x 80 mm	24.70
	167	Ceramic 14.0 mm x 90 mm	42.30
	168	Ceramic 16.0 mm x 90 mm	44.50
<b>Hex-9 Hard Ceramic Drill Bit (Replacement for CYL-9)</b>			
5	2 608 579 503	2 608 900 587 HEX-9 HardCeramic 3x90	23.60
	504	588 HEX-9 HardCeramic 4x90	24.90
	505	589 HEX-9 HardCeramic 5x90	26.00
	506	590 HEX-9 HardCeramic 6x90	27.60
	507	591 HEX-9 HardCeramic 7x90	33.30
	508	592 HEX-9 HardCeramic 8x90	33.80
	509	593 HEX-9 HardCeramic 10x90	35.00
	510	594 HEX-9 HardCeramic 12x90	42.30
	511	595 HEX-9 HardCeramic 3pc set (5/6/8)	74.30
6	2 607 017 598	2 607 017 598 Hard Tile Drilling Total Solution Set	98.50
<b>Core Drill Bit</b>			
	2 608 596 668	3 mm to 14 mm (Diameter) , 58mm (Length)	47.00
	669	5 mm to 20 mm (Diameter), 71mm (Length)	51.80

**Note:** \*Items marked are based on **Indent Basis**.

Valid in West Malaysia and while stocks last only



From the SDS inventor:

# HIGH ROBUSTNESS IN CONCRETE

The best your tool can get. Bosch Professional Accessories.





SDS-Plus shank



**SDS-plus-1**  
Optimum drilling

Standard carbide  
Standard lifetime

2-cutter

2-flute U-shape  
Standard lifetime/  
Good dust removal

## SDS Plus Drill Bit

Part Number	Description	List Price (RM)
<b>SDS Plus-1</b>		
<b>2 608 680 257</b>	4.0 x 50/110 mm	<b>8.25</b>
<b>258</b>	5.0 x 50/110 mm	<b>8.25</b>
<b>259</b>	5.0 x 100/160 mm	<b>8.90</b>
<b>260</b>	5.5 x 50/110 mm	<b>8.25</b>
<b>261</b>	5.5 x 100/160 mm	<b>8.90</b>
<b>262</b>	6.0 x 50/110 mm	<b>8.25</b>
<b>263</b>	6.0 x 100/160 mm	<b>8.90</b>
<b>264</b>	6.0 x 150/210 mm	<b>13.60</b>
<b>265</b>	6.5 x 50/110 mm	<b>8.90</b>
<b>266</b>	6.5 x 100/160 mm	<b>9.70</b>
<b>267</b>	7.0 x 50/110 mm	<b>8.90</b>
<b>268</b>	7.0 x 100/160 mm	<b>9.70</b>
<b>269</b>	8.0 x 50/110 mm	<b>8.90</b>
<b>270</b>	8.0 x 100/160 mm	<b>9.70</b>
<b>271</b>	8.0 x 150/210 mm	<b>13.70</b>
<b>272</b>	8.0 x 200/260 mm	<b>16.60</b>
<b>273</b>	10.0 x 100/160 mm	<b>10.20</b>
<b>274</b>	10.0 x 150/210 mm	<b>13.60</b>
<b>275</b>	10.0 x 200/260 mm	<b>17.90</b>
<b>276</b>	10.0 x 400/460 mm	<b>29.40</b>
<b>277</b>	12.0 x 100/160 mm	<b>10.20</b>
<b>278</b>	12.0 x 150/210 mm	<b>15.30</b>
<b>279</b>	12.0 x 200/260 mm	<b>21.00</b>
<b>280</b>	12.0 x 400/460 mm	<b>32.70</b>
<b>281</b>	14.0 x 100/160 mm	<b>15.30</b>
<b>282</b>	14.0 x 150/210 mm	<b>19.20</b>
<b>283</b>	14.0 x 200/260 mm	<b>24.40</b>
<b>284</b>	14.0 x 400/460 mm	<b>34.30</b>
<b>285</b>	16.0 x 150/210 mm	<b>22.60</b>
<b>286</b>	16.0 x 250/310 mm	<b>29.40</b>
<b>287</b>	16.0 x 400/460 mm	<b>44.50</b>
<b>288</b>	18.0 x 200/260 mm	<b>29.40</b>
<b>289</b>	18.0 x 400/460 mm	<b>51.30</b>
<b>290</b>	20.0 x 200/260 mm	<b>44.50</b>
<b>291</b>	20.0 x 400/460 mm	<b>58.70</b>
<b>292</b>	22.0 x 200/260 mm	<b>51.30</b>
<b>293</b>	22.0 x 400/460 mm	<b>66.50</b>
<b>294</b>	25.0 x 200/260 mm	<b>58.70</b>
<b>295</b>	25.0 x 400/460 mm	<b>81.60</b>
<b>2 608 579 118</b>	SDS Plus Hammer Drill Bit 6, 8, 10 x 160 mm	(3pcs set) <b>27.20</b>
<b>119</b>	SDS Plus Hammer Drill Bit 5, 6 x 110 mm, 6, 8, 10 x 160 mm	(5pcs set) <b>42.80</b>
<b>120</b>	SDS Plus Hammer Drill Bit 6 x 160 mm - 2pcs, 8, 10, 12 x 160 mm	(5pcs set) <b>45.30</b>
<b>122</b>	SDS Plus Hammer Drill Bit 6 x 160 mm	(10pcs set) <b>84.50</b>
<b>123</b>	SDS Plus Hammer Drill Bit 8 x 160 mm	(10pcs set) <b>90.00</b>
<b>124</b>	SDS Plus Hammer Drill Bit 10 x 160 mm	(10pcs set) <b>96.50</b>
<b>125</b>	SDS Plus Hammer Drill Bit 12 x 160 mm	(10pcs set) <b>96.50</b>

Valid in West Malaysia and while stocks last only.



1

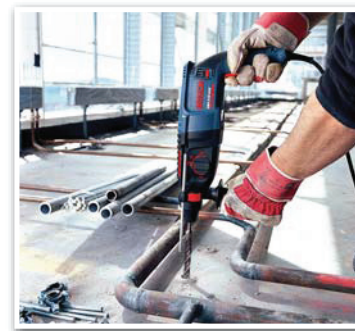

SDS-Plus shank



## SDS Plus Drill Bit

Part Number	Description	List Price (RM)
<b>SDS Plus-5 (Discontinued, while stock last basis)</b>		
2 608 579 166	4.0 x 50/115 mm	23.00
167	5.0 x 50/115 mm	16.60
168	5.0 x 100/165 mm	24.10
169	5.5 x 50/115 mm	15.60
170	5.5 x 100/165 mm	21.40
171	6.0 x 50/115 mm	16.60
172	6.0 x 100/165 mm	19.00
173	6.5 x 50/115 mm	18.50
174	6.5 x 100/165 mm	22.50
175	7.0 x 50/115 mm	19.00
176	7.0 x 100/165 mm	20.10
177	8.0 x 50/115 mm	19.50
178	8.0 x 100/165 mm	22.50
179	8.0 x 150/215 mm	35.10
180	9.0 x 100/165 mm	30.40
181	9.0 x 150/215 mm	43.00
182	10.0 x 50/115 mm	21.40
183	10.0 x 100/165 mm	23.60
184	10.0 x 200/265 mm	32.80
185	10.0 x 250/315 mm	42.00
186	10.0 x 400/465 mm	64.50
187	11.0 x 100/165 mm	28.80
188	11.0 x 150/215 mm	51.80
189	11.0 x 200/265 mm	37.30
190	12.0 x 100/165 mm	30.00
191	12.0 x 200/265 mm	41.30
192	12.0 x 400/465 mm	79.10
193	13.0 x 100/165 mm	33.30
194	13.0 x 200/265 mm	57.40
195	14.0 x 100/165 mm	36.80
196	14.0 x 150/215 mm	60.80
197	14.0 x 250/315 mm	89.00
198	15.0 x 100/165 mm	40.20
199	15.0 x 200/265 mm	62.00
200	16.0 x 150/215 mm	69.50
201	16.0 x 250/315 mm	99.00
202	16.0 x 400/465 mm	120.50
203	16.0 x 550/615 mm	144.50
204	17.0 x 150/215 mm	84.00
205	18.0 x 150/200 mm	89.50
206	18.0 x 400/450 mm	156.00
207	19.0 x 150/200 mm	109.00
208	19.0 x 250/300 mm	108.50
209	19.0 x 400/450 mm	194.00
210	20.0 x 150/200 mm	100.00
211	20.0 x 250/300 mm	109.50
212	20.0 x 400/450 mm	169.00
213	22.0 x 200/250 mm	138.00
214	22.0 x 400/450 mm	211.00
215	24.0 x 200/250 mm	164.00
216	24.0 x 400/450 mm	206.50
217	25.0 x 200/250 mm	154.00
218	25.0 x 400/450 mm	218.00
219	26.0 x 200/250 mm	183.50

Valid in West Malaysia and while stocks last only.

**SDS PLUS-5X DRILL BIT**  
**THE BEST YOUR TOOL CAN GET.**  
 Does not break when hitting rebar thanks to its 4-cutter head.  
 Bosch Professional Accessories.  
 It's in your hands.

**SDS plus-5X**  
 Does not break when hitting rebar thanks to its 4-cutter head.  
**SDS plus-5X**  
 Efficient drilling and resistant to rebar

► Suitable for masonry, concrete and reinforced concrete  
 ► Appropriate for all rotary hammers with SDS-plus holder  
 ► Full range with diameter from 5mm to 26mm

Centering tip for a deep and stable centering.  
 4-cutter The 4-cutter geometry prevents jamming in rebar. The drill bit tip does not break off.  
 Unique "turnangle" head design in combination with large and short dust removal channels provide fast dust removal and highest drilling speed without any robustness loss.  
 4-flute design Fast dust removal for higher drilling speed and less wear.

## SDS Plus Drill Bit

Part Number	Description	List Price (RM)
<b>SDS Plus-5 X</b>		
<b>2 608 833 771</b>	5x50x110mm	<b>18.70</b>
<b>774</b>	5.5x50x110mm	<b>17.55</b>
<b>775</b>	5.5x100x160mm	<b>24.20</b>
<b>777</b>	6x50x110mm	<b>18.70</b>
<b>778</b>	6x100x160mm	<b>21.90</b>
<b>781</b>	6.5x50x110mm	<b>21.90</b>
<b>782</b>	6.5x100x160mm	<b>25.20</b>
<b>786</b>	7x100x160mm	<b>23.00</b>
<b>788</b>	8x50x110mm	<b>23.00</b>
<b>789</b>	8x100x160mm	<b>25.20</b>
<b>790</b>	8x150x210mm	<b>40.50</b>
<b>796</b>	9x150x210mm	<b>49.20</b>
<b>797</b>	10x50x110mm	<b>24.20</b>
<b>798</b>	10x100x160mm	<b>26.30</b>
<b>800</b>	10x200x260mm	<b>38.30</b>
<b>801</b>	10x250x310mm	<b>48.20</b>
<b>807</b>	12x100x160mm	<b>34.00</b>
<b>809</b>	12x200x260mm	<b>47.00</b>
<b>812</b>	12x400x460mm	<b>87.00</b>
<b>813</b>	13x100x160mm	<b>39.40</b>
<b>816</b>	14x100x160mm	<b>41.60</b>
<b>817</b>	14x150x210mm	<b>69.00</b>
<b>819</b>	14x250x310mm	<b>102.00</b>
<b>825</b>	16x150x210mm	<b>78.70</b>
<b>829</b>	16x400x460mm	<b>135.50</b>
<b>2 608 836 626</b>	16x550x610mm	<b>164.00</b>
<b>628</b>	17x150x210mm	<b>94.00</b>
<b>631</b>	18x150x200mm	<b>102.00</b>
<b>633</b>	18x400x450mm	<b>177.00</b>
<b>636</b>	19x150x200mm	<b>123.50</b>
<b>637</b>	19x250x300mm	<b>123.50</b>
<b>638</b>	19x400x450mm	<b>219.50</b>
<b>639</b>	20x150x200mm	<b>114.00</b>
<b>640</b>	20x250x300mm	<b>125.00</b>
<b>641</b>	20x400x450mm	<b>192.50</b>
<b>644</b>	22x200x250mm	<b>156.50</b>
<b>645</b>	22x400x450mm	<b>239.50</b>
<b>647</b>	24x200x250mm	<b>186.00</b>
<b>648</b>	24x400x450mm	<b>234.00</b>
<b>649</b>	25x200x250mm	<b>175.00</b>
<b>650</b>	25x400x450mm	<b>246.00</b>
<b>651</b>	26x200x250mm	<b>209.00</b>

**\*\* Find out more range from us**

*Valid in West Malaysia and while stocks last only.*

SDS-Plus shank



**Asymmetric carbide teeth**  
The number of cutters is adapted to the diameter

**Fine grade high durable carbide**  
Long lifetime/  
Best wear resistance



**2-flute spiral**

> Optimised 2-flute spiral for excellent dust transportation  
> Reduces heat development and increase the lifetime

**Top grade carbide "Made by Bosch"**

> Highly durable top grade carbide tip  
> Proven cross cutter breaker design with 130° angle

**Rebar Cutting Capability**

> 4-cutter head support drilling in reinforced concrete and minimise carbide cracks  
> Design of the carbide reduce jamming while drilling in concrete



## SDS Plus Core Cutter

Part Number	Description	List Price (RM)
<b>Accessories for Core Cutters</b>		
<b>1</b>	<b>2 608 550 057</b> SDS Plus Core Cutter Mounting Shank (M16 x 105 mm)	<b>112.50</b>
	<b>2 608 598 110</b> SDS Plus Core Cutter Mounting Shank (M16 x 220 mm)	<b>160.00</b>
<b>2</b>	<b>046</b> SDS-plus shank for core cutters with M16, one-piece (175mm)	<b>209.50</b>
	<b>047</b> SDS-plus shank for core cutters with M16, one-piece (340mm)	<b>291.50</b>
	<b>048</b> SDS-plus shank for core cutters with M16, one-piece (440mm)	<b>322.00*</b>
<b>3</b>	<b>2 608 596 157</b> SDS Plus Core Cutter Pilot Drill Bit (8 x 120 mm)	<b>27.70</b>
<b>4</b>	<b>2 608 550 074</b> SDS Plus 9 Core Cutter 40 x 50/72 mm	<b>216.00</b>
	<b>075</b> SDS Plus 9 Core Cutter 50 x 50/72 mm	<b>209.50</b>
	<b>076</b> SDS Plus 9 Core Cutter 68 x 50/72 mm	<b>244.50</b>
	<b>077</b> SDS Plus 9 Core Cutter 82 x 50/72 mm	<b>255.50</b>

## SDS Max 4

### SDS Max 4 (4 cutter design)

<b>5</b>	<b>2 608 685 860</b> SDS-max 4 (16 x 200/340 mm)	<b>206.00</b>
	<b>861</b> SDS-max 4 (16 x 400/540 mm)	<b>241.50</b>
	<b>862</b> SDS-max 4 (18 x 200/340 mm)	<b>215.00</b>
	<b>863</b> SDS-max 4 (18 x 400/540 mm)	<b>255.00</b>
	<b>864</b> SDS-max 4 (20 x 200/320 mm)	<b>223.50</b>
	<b>865</b> SDS-max 4 (20 x 400/520 mm)	<b>258.50</b>
	<b>866</b> SDS-max 4 (22 x 200/320 mm)	<b>243.00</b>
	<b>867</b> SDS-max 4 (22 x 400/520 mm)	<b>274.00</b>
	<b>868</b> SDS-max 4 (25 x 200/320 mm)	<b>260.00</b>
	<b>869</b> SDS-max 4 (25 x 400/520 mm)	<b>306.00</b>
	<b>870</b> SDS-max 4 (28 x 200/320 mm)	<b>300.50</b>
	<b>871</b> SDS-max 4 (28 x 400/520 mm)	<b>345.50</b>
	<b>872</b> SDS-max 4 (30 x 200/320 mm)	<b>309.50</b>
	<b>873</b> SDS-max 4 (30 x 400/520 mm)	<b>373.50</b>
	<b>874</b> SDS-max 4 (32 x 200/320 mm)	<b>342.00</b>
	<b>875</b> SDS-max 4 (32 x 400/520 mm)	<b>404.00</b>
	<b>876</b> SDS-max 4 (35 x 400/520 mm)	<b>448.50</b>
	<b>877</b> SDS-max 4 (40 x 400/520 mm)	<b>646.50</b>

**Note:** \*Items marked are based on **Indent Basis**.

Valid in West Malaysia and while stocks last only.

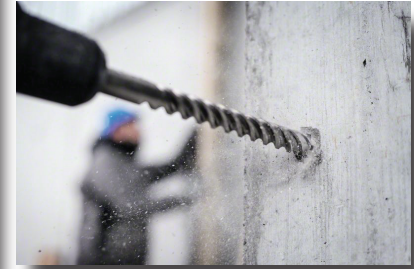

SDS-Max shank



## SDS Max Hammer Drill Bit

Part Number	<b>EXPERT</b>	Description	List Price (RM)
<b>SDS Max-7</b>			
2 608 586 797		SDS-max Speed X (35 x 600/720 mm)	979.00*
800		SDS-max Speed X (38 x 400/520 mm)	823.50*
802		SDS-max Speed X (40 x 400/520 mm)	1,001.50*
803		SDS-max Speed X (40 x 600/720 mm)	1,190.50*
807		SDS-max Speed X (52 x 400/520 mm)	1,591.00*

### SDS Max-8X (Replacement for SDS Max 7)

2 608 578 602	2 608 900 201	Hammer drill bit SDS-max-8X 12 x 200 x 340 mm	219.50
603	202	Hammer drill bit SDS-max-8X 12 x 400 x 540 mm	260.50
604	203	Hammer drill bit SDS-max-8X 12 x 600 x 740 mm	400.50
605	204	Hammer drill bit SDS-max-8X 12 x 800 x 940 mm	536.50
606	207	Hammer drill bit SDS-max-8X 14 x 200 x 340 mm	266.00
607	208	Hammer drill bit SDS-max-8X 14 x 400 x 540 mm	304.00
608	209	Hammer drill bit SDS-max-8X 14 x 600 x 740 mm	425.00
609	210	Hammer drill bit SDS-max-8X 14 x 800 x 940 mm	423.00
612	214	Hammer drill bit SDS-max-8X 16 x 200 x 340 mm	318.50
613	215	Hammer drill bit SDS-max-8X 16 x 400 x 540 mm	366.50
614	216	Hammer drill bit SDS-max-8X 16 x 600 x 740 mm	487.50
615	217	Hammer drill bit SDS-max-8X 16 x 800 x 940 mm	612.00
619	221	Hammer drill bit SDS-max-8X 18 x 200 x 340 mm	329.50
620	222	Hammer drill bit SDS-max-8X 18 x 400 x 540 mm	393.00
621	223	Hammer drill bit SDS-max-8X 18 x 600 x 740 mm	504.00
622	224	Hammer drill bit SDS-max-8X 18 x 800 x 940 mm	616.50
626	228	Hammer drill bit SDS-max-8X 20 x 200 x 320 mm	343.00
627	229	Hammer drill bit SDS-max-8X 20 x 400 x 520 mm	373.00
628	230	Hammer drill bit SDS-max-8X 20 x 600 x 720 mm	512.00
629	231	Hammer drill bit SDS-max-8X 20 x 800 x 920 mm	623.00
631	233	Hammer drill bit SDS-max-8X 22 x 200 x 320 mm	369.50
632	234	Hammer drill bit SDS-max-8X 22 x 400 x 520 mm	395.00
633	235	Hammer drill bit SDS-max-8X 22 x 600 x 720 mm	532.00
634	236	Hammer drill bit SDS-max-8X 22 x 800 x 920 mm	634.50
636	238	Hammer drill bit SDS-max-8X 24 x 200 x 320 mm	404.00
637	239	Hammer drill bit SDS-max-8X 24 x 400 x 520 mm	445.00
638	240	Hammer drill bit SDS-max-8X 25 x 200 x 320 mm	402.00
639	241	Hammer drill bit SDS-max-8X 25 x 400 x 520 mm	467.50
640	242	Hammer drill bit SDS-max-8X 25 x 600 x 720 mm	612.00
641	243	Hammer drill bit SDS-max-8X 25 x 800 x 920 mm	754.50
643	245	Hammer drill bit SDS-max-8X 26 x 200 x 320 mm	463.00
644	246	Hammer drill bit SDS-max-8X 26 x 400 x 520 mm	528.50
2 608 578 645	247	Hammer drill bit SDS-max-8X 28 x 200 x 320 mm	459.50
646	248	Hammer drill bit SDS-max-8X 28 x 400 x 520 mm	498.50
647	249	Hammer drill bit SDS-max-8X 28 x 600 x 720 mm	688.00
648	250	Hammer drill bit SDS-max-8X 28 x 800 x 920 mm	839.00
650	252	Hammer drill bit SDS-max-8X 30 x 200 x 320 mm	476.50
651	253	Hammer drill bit SDS-max-8X 30 x 400 x 520 mm	570.00
652	254	Hammer drill bit SDS-max-8X 32 x 200 x 320 mm	520.00
653	255	Hammer drill bit SDS-max-8X 32 x 400 x 520 mm	590.00
654	256	Hammer drill bit SDS-max-8X 32 x 600 x 720 mm	779.00
655	257	Hammer drill bit SDS-max-8X 32 x 800 x 920 mm	930.00

**Note:** \*Items marked are based on Indent Basis.  
Valid in West Malaysia and while stocks last only.

SDS-Plus shank (1 to 7)

SDS-Max shank (8 to 13)

19mm Hexagonal shank for USH 10 & 1 1/8" Hexagonal shank for USH 27 (14 to 20)



## SDS Plus Chisel

Part Number	Description	List Price (RM)
1 2 609 390 576	Pointed Chisel 250 mm (1 pc pack)	43.60
2 394	Flat Chisel 20 x 250 mm (1 pc pack)	43.60
3 2 608 690 101	Spade Chisel 40 x 250 mm	110.50*
4 1 618 601 004	Gouging Chisel 22 x 250 mm	126.50*
5 2 608 690 091	Tile Chisel 40 x 260 mm (1 pc pack)	159.50*
122	Pencil Chisel Flat 10 x 160 mm	132.00
120	Pencil Chisel Pointed 10 x 160 mm (10 pcs per pack)	132.00

### Hexagonal Chisel

6 2 608 684 774	Hex. Pointed Chisel 17 x 280 mm (10 pcs pack)	154.50
7 775	Hex. Flat Chisel 17 x 280 mm (10 pcs pack)	155.00
8 1 618 600 023	Pointed Chisel 280 mm	76.50*
012	Pointed Chisel 600 mm	105.50
2 608 690 128	SDS Max Pointed Chisel 400 mm (10 pcs pack)	486.00
125	SDS Max Flat Chisel 400 mm (10 pcs pack)	484.00
1 618 600 203	Flat Chisel 600 x 25 mm	101.00
9 2 608 690 097	Spade Chisel 350 x 50 mm (Self-sharpening)	114.00
1 618 601 008	Spade Chisel 300 x 80 mm	146.00
10 007	Spade Chisel 350 x 115 mm	286.50
1 618 601 019	Tile Chisel 300 x 80mm	350.00*
11 1 618 633 102	Tamping Plate 150 x 150 mm	917.00
12 1 618 609 003	Shank for Tamping Plate and Bush Hammer Head 220 mm	202.00*
13 2 608 690 167	R-Tec Pointed Chisel (twist & self sharpening) 400mm - 1 pc	96.50
168	R-Tec Pointed Chisel (twist & self sharpening) 400mm- 10 pcs pack	882.50*
14 124	R-Tec Sharp Flat Chisel (self sharpening) 400 x 25mm- 1 pc	96.50*
166	R-Tec Sharp Flat Chisel (self sharpening) 400 x 25mm- 10 pcs pack	882.50*

### For Model GSH 14C

NEW* 15 2 608 690 188	22mm Hexagonal Shank Pointed Chisel, 400mm	180.00
NEW* 16 190	22mm Hexagonal Shank Flat Chisel, 30 x 400mm	180.00

### For Model USH 27 & GSH 27

17 2 608 690 106	28 mm Hexagonal Shank Pointed Chisel, 400 mm	210.00
1 618 600 019	28 mm Hexagonal Shank Pointed Chisel, 520 mm	304.00*
18 206	28 mm Hexagonal Shank Flat Chisel, 35 x 520 mm	304.00*
19 1 618 661 000	28 mm Hexagonal Shank Spade Chisel, 80 x 400 mm	377.50*

### For Model GSH 16

20 2 608 690 111	30 mm Hexagonal Shank Pointed Chisel 400 mm	210.50
21 112	30 mm Hexagonal Flat Chisel 400 x35mm	224.00
22 113	30 mm Hexagonal Spade Chisel, 75 x 450 mm	381.50*

**Note:** \*Items marked are based on Indent Basis.

Valid in West Malaysia and while stocks last only.





# PERFECT FOR DIAMOND CUT- TING, GRINDING AND DRILLING

The best your tool can get. Bosch Professional Accessories.

17



# Bosch Diamond Accessories Catch the Speed



For angle grinder and marble cutter

## Best for Series

### Ceramic

- ▶ The right disc for the highest demands with regard to accurate, chip-free cuts, with considerably less risk of tile breakage.
- ▶ The thin cutting rim can lead to high accurate cutting.



Part number	Diameter mm	Type	Bore diameter mm	Cutting width mm	Segment height mm
2 608 603 610	105	Turbo	20 / 16	1.4	8

- ▶ Fast diamond and bond matrix helps to reduce the high temperatures caused from cutting, optimized diamond compounds enables effortless clean cut.

2 608 600 704	105	Continuous	20 / 16	1.7	5
---------------	-----	------------	---------	-----	---

### Stone

- ▶ For hard materials such as granite and natural stone.
- ▶ Hot-press that ensures stable long lifetime.

2 608 600 923	105	Segmented	20 / 16	1.7	12
---------------	-----	-----------	---------	-----	----

### Granite

2 608 615 097	110	Turbo Rim	20 / 16	2	10
---------------	-----	-----------	---------	---	----

### Concrete

- ▶ Problem solver in concrete for basic needs.
- ▶ Hot-press that ensures stable long lifetime.

2 608 600 924	105	Segmented	20 / 16	1.7	12
---------------	-----	-----------	---------	-----	----

### Universal

- ▶ Ideal for general building materials such as concrete, masonry, brick and granite.
- ▶ Excellent cutting speed thanks to its optimised diamond components.

2 608 603 740	105	Turbo	20 / 16	1.8	7
2 608 602 523	105	Segmented	20 / 16	1.7	12
2 608 602 523	105	Continuous	20 / 16	2	12

- ▶ The all-rounder in all site materials. The successful combination of long life with good performance enables effortless cutting.

2 608 602 523	105	Segmented	20 / 16	2	12
329	125	Segmented	25.4/22.3	2	12
331	180	Segmented	25.4/22.3	2.4	12
332	230	Segmented	25.4/22.3	2.4	12



# Standard for Diamond Cutting Discs

Economized spending, good performance.

Part number	Diameter mm	Type	Bore diameter mm	Cutting width mm	Segment height mm	Material
<b>2 608 603 726</b>	105	Segmented	20 / 16	1.9	7	Universal
<b>2 608 615 111</b>	125	Segmented	22.23 / 20	2.0	10	Universal
<b>113</b>	180	Segmented	25.4 / 22.23	2.4	10	Universal
<b>114</b>	230	Segmented	25.4 / 22.23	2.6	10	Universal

## Standard for Universal

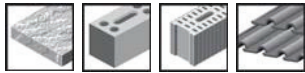

► Balanced speed and lifetime for good cutting performance in all building materials.



## Standard for Ceramic



► Fine diamond grains provide clean cutting edge and good speed for usage in ceramic.



<b>2 608 603 729</b>	105	Continuous	20 / 16	1.9	7	Ceramic
----------------------	-----	------------	---------	-----	---	---------

## Standard for Stone

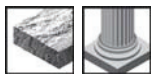

► Smooth and fast cutting especially in wet cutting application in stone.



<b>2 608 603 728</b>	105	Segmented	20 / 16	1.9	7	Stone
----------------------	-----	-----------	---------	-----	---	-------

## Standard for Concrete



► Good performance in lifetime. Efficient blade for cutting concrete.



<b>2 608 603 727</b>	105	Segmented	20 / 16	1.9	7	Concrete
----------------------	-----	-----------	---------	-----	---	----------



1



2



3



4



5



6



7



8



9



standard Concrete



standard Asphalt

## Diamond Cutting Disc

Part Number

**EXPERT**

Description

List Price  
(RM)

### Diamond Blade for Mini Grinder & Concrete Cutter

#### Best for Series

1	2 608 600 704	105 x 16/20 mm, Continuous, For Tile	41.50
2	923	105 x 16/20 mm, Segmented, For Stone (Wet & Dry Cut)	43.60
3	924	105 x 16/20 mm, Segmented, For Concrete (Dry Cut)	46.00
4	2 608 603 309	105 x 16/20 mm (12 mm Segment), Segmented, For Speed, Universal (Discontinued, while stocks last basis)	31.90
	2 608 676 934	105 x 16/20 mm (12 mm Segment), Continuous, Universal (Discontinued, while stocks last basis)	35.10
	2 608 602 523	105 x 16 /20 mm (12 mm Segment), Universal (Dry or Wet Cutting) (Replacement for 2 608 603 309 & 2 608 676 934)	46.00
	2 608 615 097	110 x 20/16mm, Turbo Rim, Granite	70.00
	2 608 603 329	125 x 25.4/22.3 mm (12 mm Segment), Segmented, Universal	66.50
	331	180 x 25.4/22.3 mm (12 mm Segment), Segmented, Universal	108.50
	332	230 x 25.4/22.3 mm (12 mm Segment), Segmented, Universal	128.50
	2 608 615 109	2 608 900 652 76 x 1.9 / 10 mm, For Tile (For GWS 12-76 V-EC)	42.80

#### Standard for Series

7	2 608 603 726	Universal, 105 x 16/20 mm	24.20
	727	Concrete, 105 x 16/20 mm	24.20
	728	Stone, 105 x 16/20 mm	24.20
	729	Ceramic, 105 x 16/20 mm	24.20
NEW*	2 608 615 232	Universal, 110 x 16/20 mm	15.50
	111	Universal, 125 x 22.23/20 mm	52.60
	113	Universal, 180 x 25.4/22.23 mm	87.50
	114	Universal, 230 x 25.4/22.23 mm	105.50

### Diamond Blade for Floor Saw

#### Standard for Concrete (Discontinued, while stocks last basis)

8	2 608 615 005	DCD Standard for Concrete (300mm x 25.4/27)	410.50
	006	DCD Standard for Concrete (350mm x 25.4/27)	581.00
	007	DCD Standard for Concrete (400mm x 25.4/27)	819.50

#### Standard for Asphalt (Discontinued, while stocks last basis)

9	2 608 615 016	DCD Standard for Asphalt (350mm x 25.4/27)	728.00
	017	DCD Standard for Asphalt (400mm x 25.4/27)	968.50
	018	DCD Standard for Asphalt (450mm x 25.4/27)	1,237.50
	019	DCD Standard for Asphalt (500mm x 25.4/27)	1,490.00

**Note:** \*Items marked are based on Indent Basis.

Valid in West Malaysia and while stocks last only.

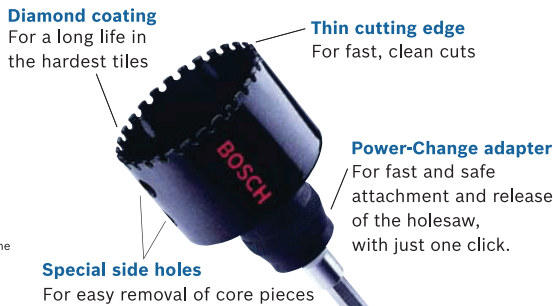
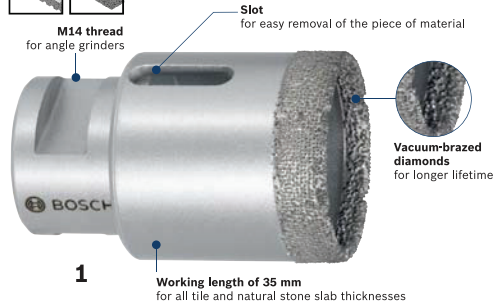
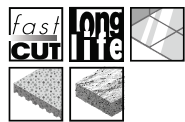

2



3



4



5

## Progressor Holesaw

Part Number	Description	Core Bit size	List Price (RM)
-------------	-------------	---------------	-----------------

**Fastest drilling into hard homogenous tiles and natural hard stone (e.g granite)**

**To be use on small angle grinder (M14 X 2.0 spindle, e.g GWS 14-125 CE) (on indent basis)**

1	2 608 587 116	Dry Speed Diamond Cutters	22 mm	426.50*
	127	Dry Speed Diamond Cutters	57 mm	416.00*
	128	Dry Speed Diamond Cutters	60 mm	441.50*
	129	Dry Speed Diamond Cutters	65 mm	464.50*
	130	Dry Speed Diamond Cutters	67 mm	733.50*
	131	Dry Speed Diamond Cutters	68 mm	498.50*
	132	Dry Speed Diamond Cutters	70 mm	634.00*
	133	Dry Speed Diamond Cutters	75 mm	653.50*
	134	Dry Speed Diamond Cutters	80 mm	567.50*
	135	Dry Speed Diamond Cutters	83 mm	871.00*
	136	Dry Speed Diamond Cutters	Core Cutter set (14, 25, 35 mm)	1,088.50*
	137	Dry Speed Diamond Cutters	Core Cutter set (25, 35, 45, 51 mm)	1,913.50*

## Diamond Drill Bits / Holesaw

Part Number	Description	Diameter	List Price (RM)	
2	2 608 599 049	Diamond tile drill bit	6 mm	62.00
	50	Diamond tile drill bit	8 mm	65.50
	51	Diamond tile drill bit	10 mm	69.00
	52	Diamond tile drill bit	12 mm	74.60
	2 607 011 626	Diamond tile drill bit set	6+6+8 mm	160.50
3	2 608 580 302	Diamond Holesaw	20 mm	123.50*
	303	Diamond Holesaw	22 mm	128.00*
	304	Diamond Holesaw	25 mm	138.00*
	305	Diamond Holesaw	29 mm	150.00*
	306	Diamond Holesaw	32 mm	164.30*
	307	Diamond Holesaw	35 mm	174.50*
	308	Diamond Holesaw	38 mm	182.50*
	394	Diamond Holesaw	41 mm	188.50*
	310	Diamond Holesaw	51 mm	239.50*
	311	Diamond Holesaw	54 mm	249.50*
4	2 608 598 142	Centring Aid for Diamond Drill Bit		134.50*
5	2 608 580 327	Centring Aid for Wet Drill Bits & Diamond Holesaw		181.50*

**Note:** \*Items marked are based on Indent Basis.

Valid in West Malaysia and while stocks last only.



22

Complete range of circular saw blades:

# INCOMPARABLE PRECISION OF CUTS

The best your tool can get. Bosch Professional Accessories.





1



2



3



4



## Circular Saw Accessories

Part Number	<b>EXPERT</b>	Description	Bore / Reduction Ring	Cutting / Blade Thickness (mm)	List Price (RM)
<b>Cordless Range</b>					
<b>NEW*</b>	<b>NEW*</b>	<b>NEW*</b>	<b>NEW*</b>	<b>NEW*</b>	<b>NEW*</b>
2 608 837 752		Cordless for multi material (for GKS 12 V-LI)	85x1.5/1x15 T30		110.00
666		Cordless for wood (for GKS 12 V-LI)	85x1.1/0.7x15 T20		90.00
685		Cordless for wood (for GKS 18V-57 & GKS 185-LI)	165x1.5/1x20 T24		100.00
702		Cordless for wood (for GKS 18V-68 GC)	184x1.6/1.1x20 T24		110.00
703		Cordless for wood (for GKS 18V-68 GC)	184x1.6/1.1x20 T48		143.00
746		Cordless for Cordless for steel (for GKM 18V-50)	184x1.6/1.1x20 T48		130.00
768		Cordless for aluminium (for GKS 18V-68 GC)	184x2/1.5x20 T56		211.00
* More cordless range available, kindly refer to sales team					
<b>Expert For Wood</b>					
1	2 608 642 970	6 1/8" 160 x 2.0 / 1.4 x 25.4 T24	20/19/16/ 5/8"		50.10
	971	6 1/8" 160 x 2.0 / 1.4 x 25.4 T40	20/19/16/ 5/8"		58.50
	972	6 1/8" 160 x 2.0 / 1.4 x 25.4 T60	20/19/16/ 5/8"		71.50
	983	7 1/4" 160 x 2.0 / 1.4 x 25.4 T30	20/19/16/ 5/8"		57.00
	984	7 1/4" 160 x 2.0 / 1.4 x 25.4 T40	20/19/16/ 5/8"		61.40
	985	7 1/4" 160 x 2.0 / 1.4 x 25.4 T60	20/19/16/ 5/8"		71.20
	999	9 1/4" 235 x 2.2 / 1.5 x 30 T40	1"/25		87.50
	2 608 643 000	9 1/4" 235 x 2.2 / 1.5 x 30 T60	1"/25		117.00
	009	10" 254 x 2.5 / 1.8 x 30 T80	1"/25		209.00
	010	10" 254 x 2.5 / 1.8 x 30 T100	1"/25		238.50
	024	12" 305 x 2.5 / 1.8 x 30 T40	1"/25/20		169.00
	026	12" 305 x 2.5 / 1.8 x 30 T80	1"/25/20		250.00
	027	12" 305 x 2.5 / 1.8 x 30 T100	1"/25/20		282.00
	033	14" 356 x 3.2 / 2.2 x 30 T60	1"/25/20		224.00
	035	14" 356 x 3.2 / 2.2 x 30 T100	1"/25/20		317.50
<b>Expert for Wood: For GCM 8SJL</b>					
	2 608 642 993	CSB expert for wood	8 1/2" 216 x 2.5 / 1.5 x 25.4 T80		166.50
	995	CSB expert for wood	8 1/2" 216 x 2.5 / 1.5 x 25.4 T60		140.00
	2 608 640 447	CSB multi material	8 1/2" 216 x 2.5 / 1.8 x 30 T80 (Reduction Ring 2600100211)		193.00
<b>Expert for Stainless Steel: For GCD 12JL</b>					
	2 608 644 284	CSB expert for stainless steel	305 x 25.4 mm x 80T		796.50*
<b>Expert for Steel : For GCD 12JL</b>					
	2 608 643 060	CSB expert for steel	12" 305 x 2.6 / 2.2 x 25.4 T60		619.00
	061	CSB expert for steel	12" 305 x 2.6 / 2.2 x 25.4 T80		701.50
<b>Non-Ferrous Metal Cutting (Aluminium)</b>					
2	2 608 642 202	Circular Saw Blade 10" x 100 TCT - 30mm / 25mm & 1"		2.7 / 2	209.00
	203	Circular Saw Blade 10" x 120 TCT - 30mm / 25mm & 1"		2.7 / 2	232.00
	209	Circular Saw Blade 12" x 100 TCT - 30mm / 20mm, 25mm & 1"		2.7 / 2	268.50
	210	Circular Saw Blade 12" x 120 TCT - 30mm / 20mm, 25mm & 1"		2.7 / 2	282.00
	213	Circular Saw Blade 14" x 100 TCT - 30mm / 20mm, 25mm & 1"		2.7 / 2	338.50
	214	Circular Saw Blade 14" x 120 TCT - 30mm / 20mm, 25mm & 1"		2.7 / 2	384.00
<b>110 mm Carbide Multi Wheel</b>					
3	2 608 642 952	2 608 901 201	110 mm Carbide Multi Wheel	20 / 16 mm	55.20
4	2 608 623 011	2 608 901 196	76 mm Carbide Multi Wheel		88.10
			(For GWS 12-76 V-EC)	10 mm	
** No more reduction ring included under Expert packaging					
<b>85mm Standard for Wood: For GKS 12V-LI</b>					
	2 608 643 071		85 x 15 x 1,1 mm, T20	15mm	51.00
<b>Eco for Wood</b>					
<b>NEW*</b>	<b>NEW*</b>				
	2 608 644 669	Eco for Wood H	110 x 20-12 (4")		17.00
	2 608 839 390	Eco for Wood H	110 x 20-40 (4")		30.00
	2 608 644 304	Eco for Wood H	184 x 25.4-30 (7")		42.80
	317	Eco for Wood H	180 x 25.4-40 (7")		53.10
	318	Eco for Wood H	184 x 25.4-60 (7")		65.00
	306	Eco for Wood B	230 x 30-60 (9")		87.60
	310	Eco for Wood B	250 x 25.4-80 (9")		110.00
	311	Eco for Wood B	250 x 25.4-100 (9")		140.50
	314	Eco for MM/ AL B	250 x 25.4-120 (9")		160.50

Note: \*Items marked are based on Indent Basis.

Valid in West Malaysia and while stocks last only.

The complete Hole Saw range:

# FOR MAXIMUM PERFORMANCE IN ALL APPLICATIONS

The best your tool can get. Bosch Professional Accessories.





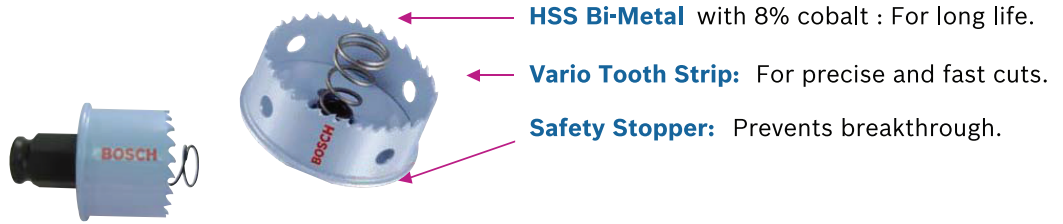

## Bi-Metal Holesaw

Part Number	EXPERT	Description	Diameter (mm/inch)	List Price (RM)
2 608 584 778		Bi-Metal Holesaw	16 mm = 5/8"	34.90
779		Bi-Metal Holesaw	17 mm = 11/16"	34.90
780		Bi-Metal Holesaw	19 mm = 3/4"	34.90
781		Bi-Metal Holesaw	20 mm = 25/32"	34.90
782		Bi-Metal Holesaw	21 mm = 13/16"	34.90
783		Bi-Metal Holesaw	22 mm = 7/8"	34.90
784		Bi-Metal Holesaw	25 mm = 1"	42.50
785		Bi-Metal Holesaw	27 mm = 1 1/16"	42.50
786		Bi-Metal Holesaw	29 mm = 1 1/8"	42.50
787		Bi-Metal Holesaw	30 mm = 1 3/16"	46.00
788		Bi-Metal Holesaw	32 mm = 1 1/4"	46.00
789		Bi-Metal Holesaw	33 mm = 1 5/16"	46.00
790		Bi-Metal Holesaw	35 mm = 1 3/8"	48.60
791		Bi-Metal Holesaw	38 mm = 1 1/2"	48.60
792		Bi-Metal Holesaw	40 mm = 1 9/16"	48.60
793		Bi-Metal Holesaw	41 mm = 1 5/8"	48.60
794		Bi-Metal Holesaw	44 mm = 1 3/4"	52.00
795		Bi-Metal Holesaw	48 mm = 1 7/8"	55.20
796		Bi-Metal Holesaw	51 mm = 2"	58.60
797		Bi-Metal Holesaw	54 mm = 2 1/8"	61.20
798		Bi-Metal Holesaw	57 mm = 2 1/4"	61.20
799		Bi-Metal Holesaw	60 mm = 2 3/8"	61.20
800		Bi-Metal Holesaw	64 mm = 2 1/2"	68.00
801		Bi-Metal Holesaw	65 mm = 2 9/16"	68.00
802		Bi-Metal Holesaw	67 mm = 2 5/8"	68.00 *
803		Bi-Metal Holesaw	68 mm = 2 11/16"	72.30 *
804		Bi-Metal Holesaw	70 mm = 2 3/4"	72.30
805		Bi-Metal Holesaw	73 mm = 2 7/8"	79.00
806		Bi-Metal Holesaw	76 mm = 3"	79.00
807		Bi-Metal Holesaw	79 mm = 3 1/8"	85.00
808		Bi-Metal Holesaw	83 mm = 3 1/4"	85.00
809		Bi-Metal Holesaw	86 mm = 3 3/8"	90.00
810		Bi-Metal Holesaw	89 mm = 3 1/2"	90.00
811		Bi-Metal Holesaw	102 mm = 4"	110.50
854		Bi-Metal Holesaw	127 mm = 5"	138.50
855		Bi-Metal Holesaw	152 mm = 6"	155.50
816		Ejection Spring		9.40 *
2 608 594 256	2 608 900 507	Power Change Plus Mandrel Hex (8.7mm) include HSS-Co pilot drill bit		101.50
257	512	Pilot drill Plus HSS-Co Ø 7.15 x 65mm		45.30 *
264	504	Power Change Plus Mandrel Hex (3/8" 8.7mm)		57.50
266	506	Power Change Plus mandrel SDS Plus		57.50

**Note :** For sizes less than 25 mm doesn't equip with spring.

**Note:** \*Items marked are based on Indent Basis.

Valid in West Malaysia and while stocks last only.

## More robustness and precision thanks to improved system

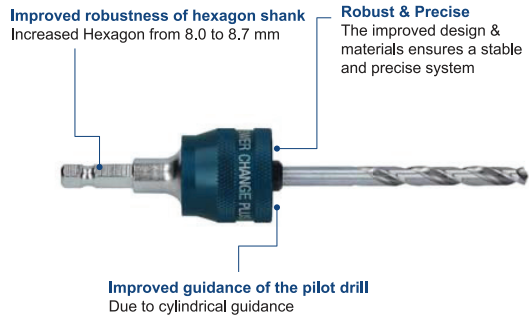

## Double Lifetime Thanks to The New Design

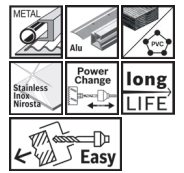
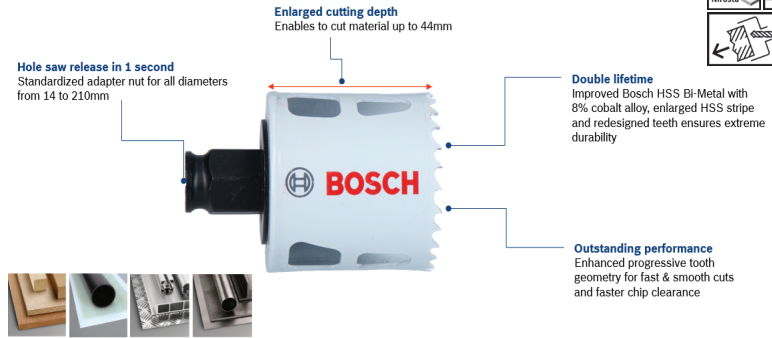

## Progressor For Wood And Metal Holesaw

Part Number **EXPERT** Description List Price (RM)

Suitable for Aluminium, Wood, Inox, Wood Laminate, Non-ferrous Material, Plastics, Steel, Cast Iron

2 608 594 195		14 mm Progressor for Wood&Metal	38.70
196		16 mm Progressor for Wood&Metal	38.70
197		17 mm Progressor for Wood&Metal	38.70
198		19 mm Progressor for Wood&Metal	38.70
199		20 mm Progressor for Wood&Metal	38.70
200		21 mm Progressor for Wood&Metal	43.10
201		22 mm Progressor for Wood&Metal	43.10
202		24 mm Progressor for Wood&Metal	43.10
203		25 mm Progressor for Wood&Metal	43.10
204		27 mm Progressor for Wood&Metal	43.10
205		29 mm Progressor for Wood&Metal	43.10
206		30 mm Progressor for Wood&Metal	43.10
207		32 mm Progressor for Wood&Metal	47.50
208		33 mm Progressor for Wood&Metal	47.50
209		35 mm Progressor for Wood&Metal	47.50
210		37 mm Progressor for Wood&Metal	49.20
211		38 mm Progressor for Wood&Metal	49.20
212		40 mm Progressor for Wood&Metal	49.20
213		41 mm Progressor for Wood&Metal	49.20
214		43 mm Progressor for Wood&Metal	52.00
215		44 mm Progressor for Wood&Metal	52.00
216		46 mm Progressor for Wood&Metal	53.50
217		48 mm Progressor for Wood&Metal	53.50
218		51 mm Progressor for Wood&Metal	59.60
219		52 mm Progressor for Wood&Metal	59.60
220		54 mm Progressor for Wood&Metal	61.20
221		56 mm Progressor for Wood&Metal	61.20
222		57 mm Progressor for Wood&Metal	61.20
223		59 mm Progressor for Wood&Metal	61.20
224		60 mm Progressor for Wood&Metal	62.50
225		64 mm Progressor for Wood&Metal	67.00
226		65 mm Progressor for Wood&Metal	67.00
227		67 mm Progressor for Wood&Metal	67.00
228		68 mm Progressor for Wood&Metal	71.20
229		70 mm Progressor for Wood&Metal	71.20
230		73 mm Progressor for Wood&Metal	71.20
231		76 mm Progressor for Wood&Metal	73.00
232		79 mm Progressor for Wood&Metal	73.00
233		83 mm Progressor for Wood&Metal	74.50
234		86 mm Progressor for Wood&Metal	74.50
235		89 mm Progressor for Wood&Metal	79.00
236		92 mm Progressor for Wood&Metal	79.00
237		95 mm Progressor for Wood&Metal	79.00
238		98 mm Progressor for Wood&Metal	98.50
239		102 mm Progressor for Wood&Metal	107.00
240		105 mm Progressor for Wood&Metal	110.50
241		108 mm Progressor for Wood&Metal	99.50
242		111 mm Progressor for Wood&Metal	110.50
243		114 mm Progressor for Wood&Metal	101.50
245		127 mm Progressor for Wood&Metal	127.00
248		152 mm Progressor for Wood&Metal	133.50
192		14 piece Universal-Set Progressor for Wood&Metal	650.50
253	2 608 900 508	Power Change Plus mandrel hex 8.7mm, incl. Drill HSS-G Ø 7.15x85 mm	81.60
254	513	Pilot drill Plus HSS-G Ø 7.15 x 8.5mm	34.20*
255	514	Pilot drill Plus HSS-Co Ø 7.15 x 8.5mm	49.20*
264	504	Power Change Plus mandrel hex 8.7mm	57.50
266	506	Power Change Plus mandrel SDS Plus	57.50
2 608 522 411	509	Power Change Plus (SDS Plus shank) incl. pilot drill HSS-G 85mm	98.50

**Note:** \*Items marked are based on Indent Basis.

Valid in West Malaysia and while stocks last only.

## Solution to BiM Sheet Metal Holesaw (cutting depth 20mm)

### Hex Shank:

**Option 1**  
**2 608 594 256**  
 65mm HSS-Co +  
 8.7mm Hex Shank



**Option 2**  
**2 608 900 504**  
**2 608 594 257**  
 New Power  
 Change Plus System +  
 8.7mm Hex Shank +  
 65mm HSS-Co



### SDS Plus Shank:

**2 608 900 506**  
**2 608 594 257**  
 SDS Plus Shank +  
 65mm HSS-Co  
 pilot drill bit



## Solution to new BiM Progressor hole saw (cutting depth 44mm)

### Hex Shank:

**Option 1**  
**2 608 900 504**  
**2 608 594 254 (HSS-G)**

**Option 2**  
**2 608 900 504**  
**2 608 594 255 (HSS-Co)**

**Option 3**  
**2 608 900 508**



85mm  
 HSS-G  
 pilot  
 drill bit



8.7mm  
 Hex Shank



85mm  
 HSS-Co  
 pilot  
 drill bit



85mm  
 HSS-G  
 pilot  
 drill bit  
 +  
 8.7mm  
 Hex Shank



### SDS Plus Shank

**Option 1**  
**2 608 900 509**



New Power  
 Change Plus System +  
 85mm Length HSS-G  
 pilot drill bit +  
 SDS Plus Shank



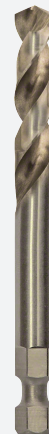

**Option 2**  
**2 608 900 506**  
**2 608 594 255**



85mm  
 HSS-Co  
 pilot  
 drill bit  
 +  
 SDS  
 Plus Shank

## Expert Sheet Metal Arbored



- 
**Tungsten Carbide Technology**  
 Increased hardness due to highest quality carbide grit with extra fine pre-alloyed powders for an extremely long lifetime. No teeth breakage due to excellent brazing process.
- 
**Optimized teeth design**  
 Extremely sharp, thin cutting edges and ideal gullet design guarantee very fast cutting speed and efficient chip removal.
- 
**Stepped pilot drill bit**  
 Prevents tip impact in order to protect the supreme quality carbide tipped teeth.
- 
**Ejection spring**  
 Guarantees automatic disc ejection for efficient continuous cutting.

Ø14 - 65 mm, **10 mm** shank  
 Ø70 - 120 mm, **13 mm** shank

Diameter (mm)	Soft Steel (min-1)	Stainless Steel (min-1)
15	850 - 1270	530 - 1060
20	640 - 950	400 - 800
30	420 - 640	270 - 530
40	320 - 480	200 - 400
60	210 - 320	130 - 270
80	160 - 240	100 - 200
100	130 - 190	80 - 160
120	110 - 160	70 - 130

## Expert Sheet Metal Arbored

Part Number	<b>EXPERT</b>	Description	List Price (RM)
<b>2 608 594 005</b>	<b>2 608 901 399</b>	TCT Hole Saw, 16 mm	<b>89.00</b>
<b>008</b>	<b>402</b>	TCT Hole Saw, 19 mm	<b>89.00</b>
<b>009</b>	<b>403</b>	TCT Hole Saw, 20 mm	<b>89.00</b>
<b>011</b>	<b>405</b>	TCT Hole Saw, 22 mm	<b>103.50</b>
<b>014</b>	<b>408</b>	TCT Hole Saw, 25 mm	<b>103.50</b>
<b>015</b>	<b>409</b>	TCT Hole Saw, 26 mm	<b>107.00</b>
<b>017</b>	<b>411</b>	TCT Hole Saw, 28 mm	<b>107.00</b>
<b>019</b>	<b>413</b>	TCT Hole Saw, 30 mm	<b>107.00</b>
<b>021</b>	<b>415</b>	TCT Hole Saw, 32 mm	<b>120.50</b>
<b>024</b>	<b>418</b>	TCT Hole Saw, 35 mm	<b>120.50</b>
<b>027</b>	<b>421</b>	TCT Hole Saw, 38 mm	<b>130.00</b>
<b>058</b>	<b>452</b>	TCT Hole Saw, Center Drill Bit	<b>19.90</b>
<b>059</b>	<b>453</b>	TCT Hole Saw, Spring	<b>2.80</b>
<b>060</b>	<b>454</b>	TCT Hole Saw, Screw	<b>2.25</b>

**Note:** \* TCT Hole Saw range available from 14 mm to 120 mm. It can be ordered based on **Indent Basis**.  
 Valid in West Malaysia and while stocks last only.



Jigsaw Blades:

# UNRIVALLED CAPABILITY IN ALL KINDS OF MATERIALS

The best your tool can get. Bosch Professional Accessories.

29





**AFFORDABLE QUALITY GET THE JOB DONE**

Name	Cutting material mm	Length mm	Tooth pitch mm	QTY pack	Part number 2608...
<b>Basic for Metal</b>					
T 118 A	Sheet metals (1-3)	68	1.1~1.5	5	631 013
T 118 B	Sheet metals (2.5-6)	68	1.9~2.3	5	631 014
T 118 G	Sheet metals (0.5-1.5)	68	0.7	5	631 012
T 318 A	Sheet metals (1-3) Thin-walled pipes & profiles (8-65)	107	1.20	5	631 319
T 318 B	Sheet metals (2.5-6) Thin-walled pipes & profiles (8-65)	108	2.0	5	631 404

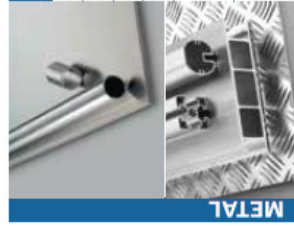

**METAL**



Name	Cutting material mm	Length mm	Tooth pitch mm	QTY pack	Part number 2608...
<b>Clean for wood</b>					
T 101 AO*	Softwood, laminated panels (1.5-15)	59	1.4	5	630 031
T 101 BR	Softwood, laminated panels (3-30)	77	2.5	5	630 014
T 101 B	Softwood (3-30)	77	2.7	5	630 030
T 101 D	Softwood (10-65)	77	4-5.2	5	630 032
T 301 CD	Softwood (10-45)	93	3	5	637 590
<b>Speed for wood</b>					
T 244 D*	Softwood (5-50)	77	4-5.2	5	630 058
T 144 D	Softwood (5-50)	77	4-5.2	5	630 040
T 344 D	Softwood, construction timber (5-100)	127	4	5	633 A34
T 744 D	Softwood, construction timber	155	4	3	663 314 *
<b>Basic for wood</b>					
T 111 C	Softwood (4-50)	77	3	5	630 033



**WOOD**

\* Especially for curve cuts

**RELIABLE PERFORMANCE: SOLUTION FOR SPECIAL APPLICATION**

Name	Cutting material mm	Length mm	Tooth pitch mm	QTY pack	Part number 2608...
<b>Speed for Metal</b>					
T 121 AF	Sheet metals (1-3)	68	1.2	5	636 699
T 121 BF	Sheet metals (2.5-6)	68	2.0	5	636 702
T 121 GF	Metal plate (0.5-1.5)	68	0.8	5	636 696
T 321 AF	Sheet metals (1-3) Thin-walled pipes & profiles (8-65)	109	1.2	5	636 705
T 321 BF	Sheet metals (2.5-6) Thin-walled pipes & profiles (8-65)	109	2.0	5	636 707
<b>Special for Alu</b>					
T 127 D	Aluminum and nonferrous metal (3-15), Pipe-profile (8-30)	77	3.0	5	631 017
T 227 D*	Aluminum and nonferrous metal (3-15), Pipe-profile (8-30)	77	3.0	5	631 030
<b>Basic for Inox</b>					
T 118 EFS	Inox / stainless steel (1.5-4)	59	1.4	5	636 420
T 118 GFS	Inox / stainless steel (0.5-1.5)	59	0.8	5	636 440

\* Especially for curve cuts

Name	Cutting material mm	Length mm	Tooth pitch mm	QTY pack	Part number 2608...
<b>Clean for Hardwood</b>					
T 101 AOF*	Hardwood, laminated panels (hardwood)	59	1.4	5	634 233 *
T 101 AIF	Hardwood, laminated panels (2-30)	77	1.7	5	634 897 *
T 101 BF	Hardwood, laminated panels (3-30)	77	2.7	5	634 234
<b>Speed for Hardwood</b>					
T 144 DF	Hardwood, softwood (5-50)	77	4-5.2	5	634 567
T 344 DF	Hardwood, softwood (5-100)	129	4	5	634 243 *

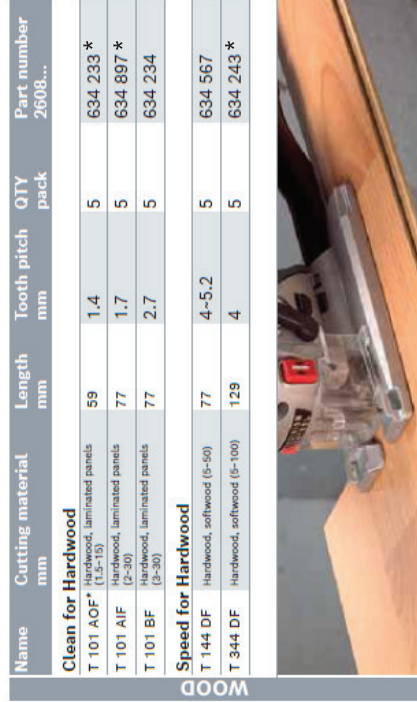

**WOOD**

\* Especially for curve cuts

Name	Cutting material mm	Length mm	Tooth pitch mm	QTY pack	Part number 2608...
<b>Carbide Special for Ceramics</b>					
T 130 RF	Ceramics	59		5	633 104
<b>Clean for</b>					
T 102 BF	PMMA	68	1.8	5	636 781
T 102 H	PVC/PA/PS sheet	77	2.3	5	667 446
T 102 D	PP/PE	77	4	5	667 444
T 302 H	PVC/PA/PS sheet & profile	109	2.3	5	667 448
T 313 AW	Capsul/ leather/ rubber (x100)	129		3	635 187 *



**Plastics & Specialties**

**Note:** \*Items marked are based on **Indent Basis**.  
Valid in West Malaysia and while stocks last only.



## Jigsaw Accessories

Part Number	<b>EXPERT</b>	Description	List Price (RM)
<b>1</b>	<b>2 607 010 079</b>	Anti-Splintering Device (5 pcs) - Applicable for all Bosch Jigsaw	<b>16.60</b>
<b>2</b>	<b>1 609 200 265</b>	Screwdriver for GST 60 / 80 PBE	<b>8.05</b>

### Jigsaw Blade Set

	<b>2 607 010 148</b>	Metal & Wood / 10 pcs Set (Discontinued, replaced by 2 607 010 630) (T 101 B, T 111 C, T 119 BO, T 118 A, T 127 D)	<b>58.60*</b>	
<b>NEW*</b>	<b>3</b>	<b>629</b>	10pcs Basic for Wood Standard Cassette (T 119 BO, T 119 B, T 111 C)	<b>65.10</b>
<b>NEW*</b>	<b>4</b>	<b>630</b>	10pcs Basic for Wood & Metal Standard Cassette (T 119 BO, T 119 B, T 111 C, T 218 A, T 118 G, T 118 A, T 118 B)	<b>58.60</b>

### Jigsaw Blade for Wood (5 pcs card)

	<b>2 608 630 014</b>	T 101 BR (Reversed teeth, fine straight cut 4 ~ 30 mm)	<b>31.50</b>
	<b>030</b>	T 101 B (Fine straight cut 4 ~ 30 mm) (Replacing T 119 B)	<b>29.30</b>
<b>5</b>	<b>031</b>	T 101 AO (Fine curved cut 2 ~ 20 mm)	<b>31.50</b>
	<b>032</b>	T 101 D (Fine straight cut 6 ~ 60 mm)	<b>33.70</b>
	<b>033</b>	T 111 C (Coarse quick cut 2 ~ 30 mm)	<b>23.20</b>
<b>6</b>	<b>040</b>	T 144 D (Straight quick cut 6 - 60 mm)	<b>29.30</b>
	<b>058</b>	T 244 D (Quick curved cut 6 ~ 60 mm)	<b>29.30</b>
	<b>2 608 663 751</b>	T 308 B Extra Clean for Wood (Straight Cut, 5 - 50 mm, 91 mm length) (5 pcs)	<b>37.50</b>
	<b>868</b>	<b>2 608 900 555</b> T 308 BO Extra Clean for Wood (Curve cut, 5 - 50 mm, 91mm length)	<b>60.70</b>

### Jigsaw Blade for Wood (3 pcs card)

	<b>2 608 637 944</b>	T 344 D** (Thick construction wood, softwood (5 - 100 mm), Clipboards, Fibre boards, Plywood) (3 pcs)	<b>21.60</b>
--	----------------------	--	--------------

### Jigsaw Blade for Wood (5 pcs card)

	<b>2 608 630 310</b>	T 119 BO (Tightest curved cut 2 ~ 20 mm)	<b>33.70</b>
	<b>2 608 633 A35</b>	T 144 DP (Parallel cut, soft wood & fibre board 5 - 50 mm)	<b>47.50</b>
	<b>2 608 637 590</b>	T 301 CD (Fine quick cut 4 ~ 60 mm)	<b>38.20</b>
<b>7</b>	<b>2 608 634 567</b>	T 144 DF (Bi-Metal/quick clean cut, wood & nail 6 ~ 60 mm)	<b>42.00</b>

**Note:** \*Items marked are based on Indent Basis.  
Valid in West Malaysia and while stocks last only.

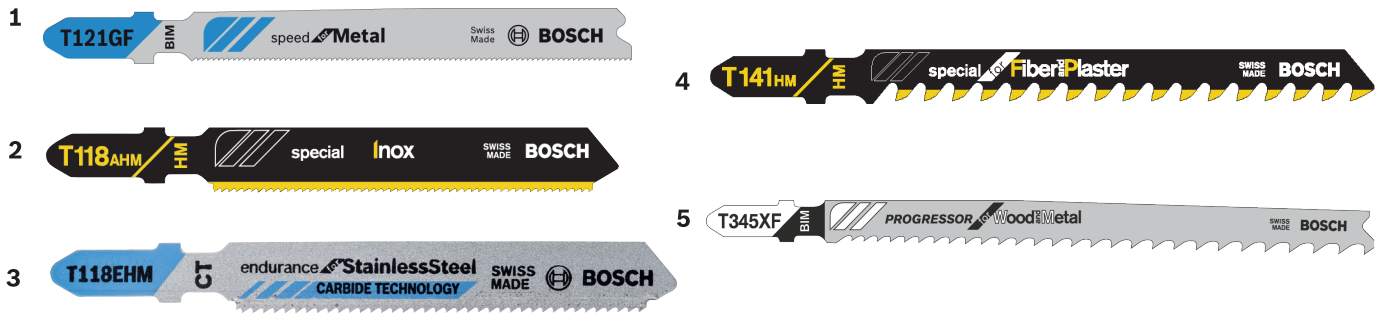

## Jigsaw Accessories

Part Number	<b>EXPERT</b>	Description	List Price (RM)
<b>Jigsaw Blade for Metal (5 pcs card)</b>			
2 608 631 010		T 101 A (Aluminium 10 mm & ideal for Perspex 2 ~ 20 mm)	<b>48.60</b>
012		T 118 G (Straight cut, Thin materials 0.2 ~ 1.0 mm)	<b>32.10</b>
013		T 118 A (Straight cut, Very Thin materials 1.5 ~ 3.0 mm)	<b>31.00</b>
014		T 118 B (Straight cut, 3 ~ 6 mm)	<b>31.00</b>
017		T 127 D (Straight quick cut, Aluminium 4 ~ 15 mm)	<b>38.20</b>
030		T 227 D (Curved cut, Aluminium 4 ~ 15 mm)	<b>37.50</b>
319		T 318 A (Straight cut, Sandwich materials 1.5 ~ 62 mm) <i>(Discontinued, replaced by T 321 AF)</i>	<b>54.60</b>
404		T 318 B (Straight curve cut, Sandwich materials 2 ~ 85 mm) <i>(Discontinued, Replaced by T321BF (BIM))</i>	<b>54.60</b>
<b>Speed Jigsaw Blade for Metal (5 pcs card)</b>			
1 2 608 636 696		T 121 GF (fine - thin sheet) 5 pcs	<b>47.00</b>
699		T 121 AF (normal - general thickness) 5 pcs	<b>47.00</b>
702		T 121 BF (coarse - thick sheets) 5 pcs	<b>47.00</b>
705		T 321 AF (normal - long blade for hollow pipe / sandwich sheets) 5 pcs	<b>75.50*</b>
707		T 321 BF (coarse - long blade for thick hollow pipe / thick sandwich sheets) 5 pcs	<b>75.50*</b>
<b>Special - Tungsten Carbide (TC) tipped Jigsaw Blade (3 pcs card)</b>			
2 2 608 630 663	2 608 900 561	T 118 AHM (Straight cut, stainless steel 1.0 ~ 2.0 mm)	<b>124.50</b>
3 665	562	T 118 EHM (Straight cut, stainless steel 2.0 ~ 4.0 mm)	<b>124.50</b>
4 2 608 633 175	563	T 141 HM (Quick cut, fibreglass & chipboard 6 ~ 60 mm)	<b>148.00</b>
176	564	T 341 HM (Quick coarse cut, aerated concrete 6 ~ 80 mm)	<b>208.50*</b>
<b>Progressor Jigsaw Blade (5 pcs card)</b>			
2 608 638 473		T 123 X Metal Progressor	<b>44.80</b>
2 608 633 528		T 234 X Wood Progressor	<b>49.20</b>
5 2 608 634 994		T 345 XF Universal Progressor	<b>55.20</b>

**Note:** \*Items marked are based on Indent Basis.  
Valid in West Malaysia and while stocks last only.





## Jigsaw Accessories

Part Number	<b>EXPERT</b>	Description	List Price (RM)
<b>Jigsaw Blade for Plastic (5 pcs card)</b>			
1	2 608 667 444	T 102 D Jig Saw Blade for PP (5pcs)	38.70
	446	T 102 H Jig Saw Blade for PVC (5pcs)	38.70
	448	T 302 H Jig Saw Blade for PVC (5pcs - long)	58.60
	2 608 636 781	T 102 BF Jig Saw Blade for PMMA (5pcs)	86.60*
	2 608 667 449	2 608 900 565 T 108 BHF Jig Saw Blade for Carbon Fiber (3pcs)	206.50*
	450	2 608 900 566 T 301CHM Jig Saw Blade for Carbon Fiber (3pcs)	302.00*
<b>Bi-Metal Jigsaw Blades for various materials (5 pcs card)</b>			
	2 608 634 503	T 118 BF (Thick material, curved cut, perspex 3 ~ 20mm) <i>(Discontinued, replaced by T121BF)</i>	48.00
2	505	T 118 AF (Straight cut, non-ferrous metals 2 ~ 10 mm) <i>(Discontinued, replaced by T121AF)</i>	48.00
	234	T 101 BF (Fine straight cut, blockboard 4 ~ 30 mm)	86.00
3	2 608 636 420	T 118 EFS (Stainless steel 1.5 ~ 4.0 mm)	52.50
4	442	T 118 GFS (Stainless steel 0.5 ~ 1.5 mm)	52.50
	2 608 636 569	2 608 900 544 T 308 BF, Extra Clean for Hard Wood, Laminated board, (Straight cut, 5 - 50 mm)	101.50
<b>For Makita (5 pcs card)</b>			
	2 608 667 854	Wood - Basic 3 x MA111C, 2 x MA 101 BC	55.20
	857	Wood/Metal - Basic 1 x T 119 BO, 1 x T 119 B, 1 x T 111 C, 1 x T 118 A, 1 x T 118 B	27.50 67.30
<b>Special for Ceramic Blade (3 pcs card)</b>			
5	2 608 633 104	Sawblade (T 130 RF) <i>(Replacing 2 608 633 R06)</i>	60.70
	105	Sawblade (T 150 RF) <i>(Discontinued, while stocks last basis; replaced by 2 608 900 567)</i>	60.70
<b>NEW*</b>	6	2 608 900 567 Sawblade (T 150 RD)	180.00

**Note:** \*Items marked are based on **Indent Basis**.  
Valid in West Malaysia and while stocks last only.



CARBIDE TECHNOLOGY

Reciprocating Saw Blades:

# LONGEST LIFETIME IN TOUGHEST MATERIALS

The best your tool can get. Bosch Professional Accessories.

34

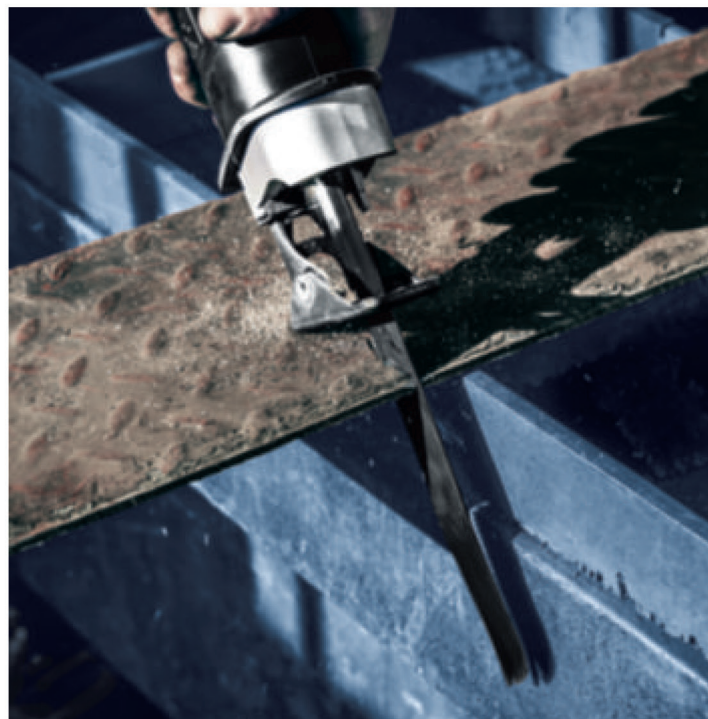

# Reciprocating Saw Blades: Carbide Series

## LONGEST LIFETIME IN TOUGHEST MATERIALS

Bosch Carbide technology cuts through the toughest materials - empowering professionals to perform with maximum efficiency.

### EXPERT 'Thick Tough Metal' Blades

ASSORTMENT: S555CHC, S955CHC, S1155CHC, S1255CHC

**EXPERT**

- 1 Extreme durability is built in with Bosch Carbide Technology
- 2 Thick gauge blade offers extra robustness and stability
- 3 Wide body for precise, straight cuts
- 4 Extra coating makes Carbide even tougher

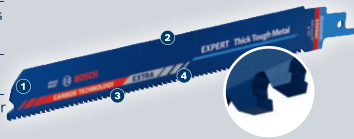

Model	Length(mm)	Pack Qty	Part No.
S 555 CHC	100	1	2 608 900 364
S 955 CHC	150	1	2 608 900 365
S 1155 CHC	225	1	2 608 900 368
S 1255 CHC	300	1	2 608 900 371

### EXPERT 'Thin Tough Metal' Blades

ASSORTMENT: S522EHM, S922EHM, S1022EHM

**EXPERT**

- 1 Extreme durability is built in with Bosch Carbide Technology
- 2 Extra-fine teeth cut very thin material with ease



Model	Length(mm)	Pack Qty	Part No.
S 522 EHM	115	1	2 608 900 359
S 922 EHM	150	1	2 608 900 360
S 1022 EHM	200	1	2 608 900 363

### EXPERT 'Cement Cast Iron' Blades

ASSORTMENT: S1750RD

**EXPERT**

- 1 Extremely durable cutting edge using Bosch Diamond Technology
- 2 Thick gauge blade offers extra robustness and stability



Model	Length(mm)	Pack Qty	Part No.
S 1750 RD	250	1	2 608 900 383

### EXPERT 'Window Demolition' Blades

ASSORTMENT: S956DHM

**EXPERT**

- 1 Extreme durability is built in with Bosch Carbide Technology
- 2 Tapered tip reaches deeper into tight spaces
- 3 Side set teeth to cut thicker materials effectively
- 4 First tooth designed to allow plunge cut



Model	Length(mm)	Pack Qty	Part No.
S 956 DHM	150	1	2 608 900 385

### EXPERT 'Medium-Thick Tough Metal' Blades

ASSORTMENT: S955HHM, S1155HHM, S1255HHM

**EXPERT**

- 1 Extreme durability is built in with Bosch Carbide Technology
- 2 Wide body for precise, straight cuts
- 3 Fine teeth cut thinner material with ease



Model	Length(mm)	Pack Qty	Part No.
S 955 HHM	150	1	2 608 900 373
S 1155 HHM	225	1	2 608 900 374
S 1255 HHM	300	1	2 608 900 377

### EXPERT 'Vehicle Rescue' Blades

ASSORTMENT: S957CHM, S1157CHM

**EXPERT**

- 1 Extreme durability is built in with Bosch Carbide Technology
- 2 Thick gauge blade offers extra robustness and stability
- 3 First tooth designed to allow plunge cut
- 4 Tapered tip reaches deeper into tight spaces



Model	Length(mm)	Pack Qty	Part No.
S 957 CHM	150	1	2 608 900 378
S 1157 CHM	225	1	2 608 900 380

### EXPERT 'Wood with Metal Demolition' Blades

ASSORTMENT: S967XHM, S1167XHM, S1267XHM

**EXPERT**

- 1 Extreme durability is built in with Bosch Carbide Technology
- 2 Reinforced teeth withstand the extreme abuse of demolition work
- 3 Progressive tooth pitch to cut material of every thickness
- 4 Tapered tip reaches deeper into tight spaces
- 5 Thick gauge blade offers extra robustness and stability



Model	Length(mm)	Pack Qty	Part No.
S 967 XHM	150	1	2 608 900 396
S 1167 XHM	225	1	2 608 900 398
S 1267 XHM	300	1	2 608 900 401

**Note :** Item marked in red are based on Indent Basis.  
Valid in West Malaysia and while stocks last only.

## EXPERT 'Hard Nail Pallets' Blades

ASSORTMENT: S1122CHM

EXPERT

- 1 Extreme durability is built in with Bosch Carbide Technology
- 2 Highly flexible body can be bent for flush cuts
- 3 Reverse tip prevents jamming and kickback
- 4 Reinforced shank transition for longer shank life



CARBIDE TECHNOLOGY

Model	Length(mm)	Pack Qty	Part No.
S 1122 CHM	225	1	2 608 900 387

## EXPERT 'Multi Material' Blades

ASSORTMENT: S956XHM, S1156XHM, S1256XHM

EXPERT

- 1 Extreme durability is built in with Bosch Carbide Technology
- 2 Progressive tooth pitch to cut material of every thickness
- 3 Tapered tip reaches deeper into tight spaces
- 4 Thick gauge blade offers extra robustness and stability
- 5 Wide body for precise, straight cuts



CARBIDE TECHNOLOGY

Model	Length(mm)	Pack Qty	Part No.
S 956 XHM	150	1	2 608 900 389
S 1156 XHM	225	1	2 608 900 391
S 1256 XHM	300	1	2 608 900 394

## EXPERT 'Aerated Concrete' Blades

ASSORTMENT: S1141HM, S1241HM, S2041HM

EXPERT

- 1 Extreme durability is built in with Bosch Carbide Technology
- 2 Thick gauge blade offers extra robustness and stability
- 3 Wide body for precise, straight cuts
- 4 Large gullet teeth chew through the toughest materials fast



CARBIDE TECHNOLOGY

Model	Length(mm)	Pack Qty	Part No.
S 1141 HM	225	1	2 608 900 408
S 1241 HM	300	1	2 608 900 410
S 2041 HM	400	1	2 608 900 413

## EXPERT 'Tough Wood' Blades

ASSORTMENT: S1142KHM, S1242KHM

EXPERT

- 1 Extreme durability is built in with Bosch Carbide Technology
- 2 Tapered tip reaches deeper into tight spaces
- 3 Thick gauge blade offers extra robustness and stability
- 4 Wide body for precise, straight cuts
- 5 Large gullet teeth chew through the toughest materials fast



CARBIDE TECHNOLOGY

Model	Length(mm)	Pack Qty	Part No.
S 1142 KHM	225	1	2 608 900 403
S 1242 KHM	300	1	2 608 900 406

## EXPERT 'Wood with Metal' Blades

ASSORTMENT: S715LHM

EXPERT

- 1 Extreme durability is built in with Bosch Carbide Technology
- 2 Narrow blade is perfect for curved cuts



CARBIDE TECHNOLOGY

Model	Length(mm)	Pack Qty	Part No.
S 715 LHM	190	1	2 608 900 384

## EXPERT 'Hollow Brick' Blades

ASSORTMENT: S1543HM, S1243HM, S2243HM

EXPERT

- 1 Extreme durability is built in with Bosch Carbide Technology
- 2 Thick gauge blade offers extra robustness and stability
- 3 Wide body for precise, straight cuts
- 4 Large gullet teeth chew through the toughest materials fast

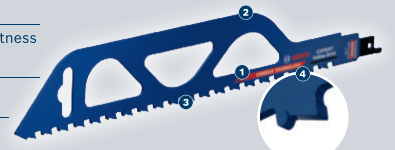

CARBIDE TECHNOLOGY

Model	Length(mm)	Pack Qty	Part No.
S 1243 HM	300	1	2 608 900 417
S 1543 HM	240	1	2 608 900 414
S 2243 HM	455	1	2 608 900 418

## EXPERT 'Fiber Plaster' Blades

ASSORTMENT: S641HM

EXPERT

- 1 Extreme durability is built in with Bosch Carbide Technology
- 2 Tapered tip reaches deeper into tight spaces
- 3 Thick gauge blade offers extra robustness and stability



CARBIDE TECHNOLOGY

Model	Length(mm)	Pack Qty	Part No.
S 641 HM	150	1	2 608 900 407

**Note:** \*Items marked are based on Indent Basis.  
Valid in West Malaysia and while stocks last only.



Model	Part Number	Application	Description	List Price (RM)
-------	-------------	-------------	-------------	-----------------

**Bi - Metal Range - For Model GSA 1100 E, GSA 1200 PE & GSA 1200 E (5 pcs pack)**

	<b>S 922EF</b>	<b>2 608 656 015</b>	Flexible for metal	Thin cut (150 x 19 x 0.9), metal (1.5 - 4 mm), closed pipe/profile (<100 mm). 18 TPI (BiM/milled)	<b>65.10</b>
	<b>S 1122EF</b>	<b>020</b>	Flexible for metal	Flush cut (225 x 19 x 0.9), thin metal (1.5 - 4 mm), closed pipe/profile (<175 mm). 18 TPI (BiM/milled)	<b>90.00</b>
<b>1</b>	<b>S 922BF</b>	<b>014</b>	Flexible for metal	Fast cut (150 x 19 x 0.9), metal (3 - 8 mm), closed pipe/profile (<100 mm). 14 TPI (BiM/milled)	<b>65.10</b>
<b>2</b>	<b>S 1122BF</b>	<b>019</b>	Flexible for metal	Flush fast cut (225 x 19 x 0.9), thick metal (3 - 8 mm), closed pipe/profile (<175 mm) 14 TPI (BiM/milled)	<b>90.00</b>
	<b>S 522EF</b>	<b>012</b>	Progressor for Metal	(100 x 19 x 0.9mm), Thin sheet metals (1.5 - 4 mm). 18 TPI (BiM/milled) <b>(Replacement for S 522 AF)</b>	<b>62.50*</b>
<b>3</b>	<b>S 927 BEF</b>	<b>2 608 657 523</b>	Endurance for Heavy Metal	Fine & precise cut (150 x 25 x 0.9), medium-thick to thick sheet metals (3-8mm), thin-walled closed and open profiles and pipes (<100mm), 14+18 TPI (BiM)	<b>98.50</b>
<b>4</b>	<b>S 1127BEF</b>	<b>2 608 657 524</b>	Endurance for Heavy Metal	Fine & precise cut (225 x 25 x 0.9), medium-thick to thick sheet metals (3-8mm), thin-walled closed and open profiles and pipes (<175mm).	<b>104.50</b>
<b>5</b>	<b>S 1227BEF</b>	<b>2 608 658 147</b>	Endurance for Heavy Metal	Fine, precise cuts (300 x 25 x 0.9), medium-thick to thick sheet metals (3-8mm), thin-walled closed and open profiles and pipes (<250mm).	<b>120.50</b>
<b>6</b>	<b>S 936 CHF</b>	<b>2 608 657 525</b>	Endurance for Heavy Metal	Fast cut (150 x 25 x 1.1), thick sheet metals (4-12mm), thick-walled closed and open profiles and pipes (<100mm), 8+10 TPI (BiM)	<b>120.50</b>
<b>7</b>	<b>S 1136CHF</b>	<b>2 608 657 526</b>	Endurance for Heavy Metal	Fast and precise cut (225 x 25 x 1.1), thick sheet metals (4-12mm), thick-walled closed and open profiles and pipes (<175mm), 8+10 TPI (BiM)	<b>136.00</b>

**Note:** \*Items marked are based on **Indent Basis**.  
Valid in West Malaysia and while stocks last only.



## Sabresaw Blade & Reciprocating Saw Blade

Model	Part Number	Application	Description	List Price (RM)
<b>High Carbon Steel / Bi-Metal Range - For Model GSA 1100 E, GSA 1200 PE &amp; GSA 1200 E (5 pcs pack)</b>				
<b>S 644D</b>	<b>2 608 650 673</b>	Top for wood	Clean Cut (150 x 19 x 1.25), construction wood (<100mm). 6 TPI (HCS/ground)	<b>58.00</b>
<b>S 1531L</b>	<b>676</b>	Top for wood	Fast cut (240 x 19 x 1.5), coarse wood (<190 mm). 5 TPI (HCS/ground)	<b>121.50</b>
<b>NEW* S 1542K</b>	<b>682</b>	Top for Wood	Fast cut (240 x 19 x 1.5), Firewood, damp wood (<190 mm). 5 TPI (HCS/ground) (Replacement for S1111K)	<b>92.00</b>
<b>S 1122VF</b>	<b>2 608 654 981</b>	Flexible for wood and metal	Flush cut (225 x 19 x 0.9), wood/metal (<175 mm), alu profile (3 - 10 mm), plastic profile (<175 mm). 10 - 14 TPI (BiM/milled)	<b>90.50*</b>
<b>S 1222VF</b>	<b>2 608 656 022</b>	Flexible for wood and metal	Flush cut (300 x 19 x 0.9), wood/metal (<250 mm), alu profile (3 - 10 mm), plastic profile (<250 mm). 10 - 14 TPI (BiM/milled)	<b>112.00*</b>
<b>S 511DF</b>	<b>2 608 657 723</b>	Heavy for wood and metal	Fast cut (100 x 19 x 0.9 mm), wood with nail/ metal, chipboard, plastic pipe, epoxy. 6 TPI (BiM/milled) (For Model GSA 12V-LI)	<b>73.00</b>
<b>S 1411DF</b>	<b>2 608 654 763</b>	Heavy for wood and metal	Fast cut (300 x 19 x 1.25), wood/metal (<250 mm), fibre glass (<60mm). 6 TPI (BiM/milled)	<b>91.00*</b>
<b>S 3456XF</b>	<b>406</b>	Progressor for wood and metal	Power cut (200 x 19 x 1.25), wood/metal (<150 mm), alu profile (3 - 18 mm), fibre glass (<150 mm). 6 - 12 TPI (BiM/milled)	<b>119.50</b>
<b>NEW* S 611DF</b>	<b>2 608 656 258</b>	Heavy for Wood and Metal	Plunge cut (150 x 22 x 1.25), Wood with nails/metal, chipboard (<100 mm), plastic profiles (<100 mm), plastics/glass fibre reinforced plastic, solid (<50 mm). 6 TPI (BiM/milled) (Replacement for S711DF)	<b>90.50*</b>

**Note:** \*Items marked are based on Indent Basis.  
Valid in West Malaysia and while stocks last only.

Expert Thick Tough Material

Progressor for Wood / Metal



Endurance for Aerated Concrete



Endurance for Vehicle Rescue



## Sabresaw Blade & Reciprocating Saw Blade

Model	Part Number	EXPERT	Application	Description	List Price (RM)
<b>Carbide Range</b>					
S 956XHM	2 608 653 099	2 608 900 389	Progressor for wood/metal	(150 x 25 x 1.25) Progressor for Wood + Metal CT (1 piece pack)	101.50
S 1156XHM	2 608 653 100	391	Progressor for wood/metal	(225 x 25 x 1.25) Progressor for Wood + Metal CT (1 piece pack)	139.00*
S 1141HM	2 608 650 971	408	Endurance for Aerated Concrete	(225 x 19 x 1.25), concrete, red brick, fibre cement (<175mm), glass fibre reinforced plastic/epoxy (<150mm), 3 TPI (Ground) (1 piece pack)	110.00
S 1241HM	2 608 650 972	410	Endurance for Aerated Concrete	(300 x 22 x 1.5), concrete, red brick, fibre cement (<250mm), glass fibre reinforced plastic/epoxy (<150mm), 3 TPI (Ground) (1 piece pack)	139.50
S 957CHM	2 608 653 130	378	Endurance for Vehicle Rescue	(150 x 10 x 1.35) Plunge Cutting Capability, Specific rescue techniques such as roof cut and 3rd door. (1 piece pack)	108.00*
S 1157CHM	2 608 653 132	380	Endurance for Vehicle Rescue	(225 x 20 x 1.35) Plunge Cutting Capability, Specific rescue techniques such as roof cut and 3rd door. (1 piece pack)	146.00*
S 922EHM	2 608 653 097	360	Endurance for Stainless Steel	(150 x 19 x 1.0) For cutting stainless, hardened & high-alloy steel. Smooth sawing, (1 piece pack)	139.00
S 1155CHM	2 608 653 182		Endurance for Heavy Metal	(225 x 25 x 1.25 mm) Precise cutting, for heavy gauge cast iron, hardened steel, high-alloy profile, pipe and tube. (1 piece pack) <i>(Discontinued, replaced by S 1155CHC)</i>	115.00*
<b>NEW*</b> S 1155CHC		368	Expert Thick Tough Material	(225 x 25 x 1.25 mm) Perfect for straight cuts, for tough steel, Cast iron (1 piece pack)	115.00
<b>NEW*</b> S 715LHM		384	EXPERT Wood with Metal	(190 x 12 x 1.5 mm) Curved cuts, for wood with tough metal, Construction wood with mortar and nails. (1 piece pack) <i>(Replacement for S 711DF)</i>	70.00

**Note:** \*Items marked are based on Indent Basis.  
Valid in West Malaysia and while stocks last only.

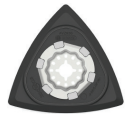

1



2



3



4



5

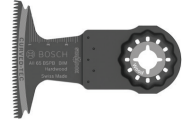

6



7



8



9

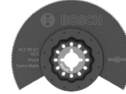

10



11



12

## Cordless Multi-Cutter Accessories

Part Number	EXPERT	Model	Description	Quantity	Diameter	List Price (RM)
<b>Grinding</b>						
<b>For Model GOP 12V-28, GOP 18V-28, GOP 30-28</b>						
1	2 608 000 493	AVZ 93G	Delta Sanding Plate	1	93 mm	60.00
	2 608 607 540	RedWoodTop (Set)	Delta Sanding Sheet Mixed Sets (10pcs/set)	10	93 mm	41.60
2	2 608 661 629	AIZ 32 APB	BIM, Wood+Metal, Curved-Tec	5	32 x 50 mm	221.50
3	630	AIZ 32 BSPB	BIM, Hardwood, Curved-Tec	5	32 x 50 mm	221.50
4	626	AIZ 32 EPC	HCS, Wood, Curved-Tec	5	32 x 50 mm	216.50
5	628	AIZ 20 AB	BIM, Wood+Metal	5	20 x 30 mm	216.50
<b>Plungecut (Wide)</b>						
6	2 608 662 017	All 65 BSPB	BIM, Hardwood, Curved-Tec	1	65 x 40 mm	86.00
<b>Plungecut (Narrow)</b>						
7	2 608 661 641	AIZ 10 AB	BIM, Wood + Metal	1	10 x 20 mm	53.50
5	640	AIZ 20 AB	BIM, Wood+Metal	1	20 x 30 mm	53.60
2	644	AIZ 32 APB	BIM, Wood+Metal, Curved-Tec	1	32 x 50 mm	55.20
3	645	AIZ 32 BSPB	BIM, Hardwood, Curved-Tec	1	32 x 50 mm	55.20
4	637	AIZ 32 EPC	HCS, Wood, Curved-Tec	1	32 x 50 mm	53.60
8	2 608 662 018 2 608 900 014	AIZ 32 AT	Carbide, Metal	1	20 x 40 mm	116.00*
<b>Segment Sawing</b>						
9	2 608 661 636	ACZ 85 EB	BIM, Wood+Metal	1	85 mm	98.50
10	643	ACZ 85 EC	HCS, Wood	1	85 mm	90.50
<b>Carbide RIFF</b>						
11	2 608 661 642	ACZ 85 RT3	Carbide, Grout+Abrasive	1	85 mm	136.00
12	689	ACZ 85 RD4	Diamond, Grout + Abrasive	1	85 mm	353.00*

**Note:** \*Items marked are based on **Indent Basis**.  
Valid in West Malaysia and while stocks last only.



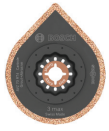

13



14



15

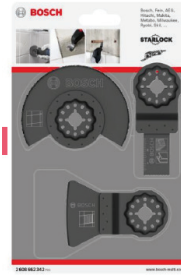

19



20



21



16



17



18

## Cordless Multi-Cutter Accessories

	Part Number	<b>EXPERT</b>	Model	Description	Quantity	Diameter	List Price (RM)
<b>Carbide RIFF</b>							
13	2 608 661 757	2 608 900 041	AVZ 70 RT4	Carbide, Grout+Abrasive	1	70 mm	<b>186.50</b>
14	868		AIZ 32 RT5	Carbide, Grout+Abrasive	1	32 x 30 mm	<b>81.60</b>

### Knife/Scraper

15	2 608 661 646		ATZ 52 SC	HCS, Multi Material	1	52 x 26 mm	<b>48.00</b>
16	647		ATZ 52 SFC	HCS, Multi Material	1	52 x 45 mm	<b>60.00</b>
17	693		ACZ 100 SWB	BIM, Multimaterial, Serrated	1	100mm	<b>186.50*</b>
18	691		AIZ 28 SC	HCS, Multi Material	1	28 x 40 mm	<b>45.00</b>

### Set

19	2 608 662 342		Carbide Blade/Grout, Scraper/Grout, Plungecut Blade/Metal + Wood	3pcs Basic Tile Set			<b>167.00</b>
20	343		Segment Blade/Wood, Plungecut Blade/Wood, Plungecut Blade/Wood + Metal	3pcs Basic Wood Set			<b>167.00</b>
21	2 608 661 694		ACZ85EB, AIZ32APB, ATZ52SFC, 10pcs Expert for Wood&Paint	13 pcs universal set			<b>253.50</b>

**Note:** \*Item marked are based on **Indent Basis**.  
Valid in West Malaysia and while stocks last only.

**XLOCK**

X-LOCK the ultimate  
changing system for grinders:

# PERFECT FOR CUTTING, GRINDING AND BRUSHING

The best your tool can get. Bosch Professional Accessories.





1



3



5



2



4



6



7



## Bonded & Coated Abrasive. Accessories for Angle Grinder & Cut Off Machine

Part Number	<b>EXPERT</b>	Description	List Price (RM)
<b>Bonded Abrasive for Angle Grinder &amp; Cut Off Machine</b>			
<b>Grinding Disc</b>			
1	2 608 602 267	Inox Grinding Disc (4" x 5.8 x 16.0 mm)	4.50
	2 608 600 434	4" Flexible Inox / Stainless Steel Grinding Disc (4" x 3.0 x 16.0mm) (Discontinued, while stocks last)	5.75*
	2 608 620 690	Flexible Grinding Disc (100 x 2.8 x 16.0 mm) (Replacement for 2608 600 434)	4.20*
	2 608 600 017	Grinding Disc (4" x 6.0 x 16.0 mm)	3.60
	263	Grinding Disc (5" x 6.0 x 22.2 mm)	6.00
	264	Grinding Disc (7" x 6.0 x 22.2 mm)	7.70
	265	Grinding Disc (9" x 6.0 x 22.2 mm)	16.20
	2 608 601 705	76mm Inox Grinding Disc (76 x 4 x 10mm) (2pcs pkt) (For GWS 12-76 V-EC)	30.60
	2 608 602 379	Grinding Disc (7" x 6.0 x 22.2 mm) (Strictly for indent, MOQ: 1200pcs)	7.00*
<b>Cutting Disc</b>			
2	2 608 601 520	Cutting Disc - Inox (76 x 1.0 x 10mm)( 5pcs ) (For GWS 12-76 V-EC)	34.60
3	2 608 901 468	Cutting Disc- 4" Expert for Inox (105 x 1.0 x 16.0mm)	4.60
4	2 608 607 414	Cutting Disc - Stainless Steel (4" x 1.0 x 16.0 mm)	4.50
	2 608 603 412	Cutting Disc - Metal (105mm x 1.2 x 16.0mm)	2.75
5	2 608 619 343	Cutting Disc - Standard for Metal (4" x 1.2 x 16.0mm)	2.20
6	2 608 619 701	Cutting Disc - Metal / Stainless Inox (4" x 1.2 x 16.0mm)	2.35
NEW*	2 608 619 766	Cutting Disc - Standard for Metal (14" x 2.8 x 25.4mm)	16.00
	2 608 600 266	Cutting Disc (thin) - Steel (4" x 1.2 x 16.0 mm)	4.00
	091	Cutting Disc - Steel (4" x 2.5 x 16.0 mm)	3.60
	270	Cutting Disc - Steel (5" x 3.0 x 22.2 mm)	4.50
	272	Cutting Disc - Steel (7" x 3.0 x 22.2 mm)	7.20
	274	Cutting Disc - Steel (9" x 3.3 x 22.2 mm)	11.50
	275	Cutting Disc - Stone (9" x 3.0 x 22.2 mm) (Discontinued, While stocks last)	12.60*
	276	Cutting Disc - Steel (12" x 3.0 x 25.4 mm)	20.60
	277	Cutting Disc - Steel (14" x 3.0 x 25.4 mm)	20.40
	2 608 619 276	Cutting Disc for Heavy Metal (14" x 3.0 x 25.4mm )	22.60
	2 608 602 751	Cutting Disc - Steel (14" x 3.0 x 25.4 mm) - Economy Speed Cut	14.80
	2 608 600 428	Cutting Disc - Steel (16" x 3.6 x 25.4 mm)	34.00
7	2 608 900 531	2 608 900 531 Diamond Metal Cutting (105x20/16mm)	106.00

Note: \*Item marked are based on Indent Basis. MOQ of 600 pcs required  
Valid in West Malaysia and while stocks last only.



## Bonded & Coated Abrasive. Accessories for Angle Grinder & Straight Grinders

Part Number	<b>EXPERT</b>	Description	List Price (RM)
<b>Flap Disc</b>			
<b>1</b>	<b>2 608 601 675</b>	100mm - Alox Flap Disc - Grit 36	<b>8.05</b>
	<b>676</b>	100mm - Alox Flap Disc - Grit 60	<b>8.05</b>
	<b>677</b>	100mm - Alox Flap Disc - Grit 80	<b>8.05</b>
	<b>678</b>	100mm - Alox Flap Disc - Grit 120	<b>8.05</b>
<b>NEW* Flap Disc, Best for Metal (Replacement for Flap Disc For Stainless Steel)</b>			
<b>2</b>	<b>2 608 619 326</b>	100mm X571, best for metal, grit 40	<b>13.20</b>
	<b>327</b>	100mm X571, best for metal, grit 60	<b>13.20</b>
	<b>328</b>	100mm X571, best for metal, grit 80	<b>13.20</b>
	<b>329</b>	100mm X571, best for metal, grit 120	<b>13.20</b>
<b>Flexible Flap Disc</b>			
<b>3</b>	<b>2 608 603 699</b>	100mm Flexible Flap Disc (P40)	<b>7.15</b>
	<b>700</b>	100mm Flexible Flap Disc (P60)	<b>7.15</b>
	<b>701</b>	100mm Flexible Flap Disc (P80)	<b>7.15</b>
	<b>702</b>	100mm Flexible Flap Disc (P100)	<b>7.15</b>
	<b>703</b>	100mm Flexible Flap Disc (P120)	<b>7.15</b>
	<b>704</b>	100mm Flexible Flap Disc (P150)	<b>7.15</b>
	<b>705</b>	100mm Flexible Flap Disc (P180)	<b>7.15</b>
	<b>706</b>	100mm Flexible Flap Disc (P220)	<b>7.15</b>
	<b>707</b>	100mm Flexible Flap Disc (P320)	<b>7.15</b>
<b>Fibre Disc</b>			
<b>4</b>	<b>2 608 608 N92</b>	Ø 100 X 16mm Brown Aluminium Oxide P24 (50pcs/box)	<b>1.90/pc</b>
	<b>N93</b>	Ø 100 X 16mm Brown Aluminium Oxide P36 (50pcs/box)	<b>1.90/pc</b>
	<b>N94</b>	Ø 100 X 16mm Brown Aluminium Oxide P60 (50pcs/box)	<b>1.90/pc</b>
	<b>N95</b>	Ø 100 X 16mm Brown Aluminium Oxide P80 (50pcs/box)	<b>1.90/pc</b>
	<b>N96</b>	Ø 100 X 16mm Brown Aluminium Oxide P100 (50pcs/box)	<b>1.90/pc</b>
	<b>N97</b>	Ø 100 X 16mm Brown Aluminium Oxide P120 (50pcs/box)	<b>1.90/pc</b>
<b>Strip Disc</b>			
<b>5</b>	<b>2 608 619 287</b>	4" Inch Clean & Strip Disc	<b>18.80</b>
<b>Bosch Net M480 (for GTR 550)</b>			
<b>6</b>	<b>2 608 621 180</b>	<b>2 608 900 707</b> Net, 225mm, 80, 25x	<b>227.00</b>
	<b>181</b>	<b>708</b> Net, 225mm, 100, 25x	<b>227.00</b>
	<b>182</b>	<b>709</b> Net, 225mm, 120, 25x	<b>227.00</b>
	<b>183</b>	<b>710</b> Net, 225mm, 150, 25x	<b>227.00</b>
	<b>184</b>	<b>711</b> Net, 225mm, 180, 25x	<b>227.00</b>
	<b>185</b>	<b>712</b> Net, 225mm, 220, 25x	<b>227.00</b>
	<b>186</b>	<b>713</b> Net, 225mm, 240, 25x	<b>227.00</b>
	<b>187</b>	<b>714</b> Net, 225mm, 320, 25x	<b>227.00</b>
	<b>188</b>	<b>715</b> Net, 225mm, 400, 25x	<b>227.00</b>

Valid in West Malaysia and while stocks last only.



1

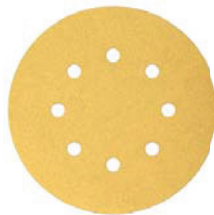

2



## Coated Velcro Disc

Part Number	Description	List Price (RM)
<b>Coated C411 Velcro Disc, 125mm diameter, 6 holes</b>		
1	2 608 608 T51	125mm - 6 holes, Grit 60# (50pcs/box) 1.40
	T52	125mm - 6 holes, Grit 80# (50pcs/box) 1.40
	T53	125mm - 6 holes, Grit 100# (50pcs/box) 1.40
	T54	125mm - 6 holes, Grit 120# (50pcs/box) 1.40
	T55	125mm - 6 holes, Grit 150# (50pcs/box) 1.40
	T56	125mm - 6 holes, Grit 180# (100pcs/box) 1.40
	T57	125mm - 6 holes, Grit 220# (100pcs/box) 1.40
	T58	125mm - 6 holes, Grit 240# (100pcs/box) 1.40
	T59	125mm - 6 holes, Grit 280# (100pcs/box) 1.40
	T60	125mm - 6 holes, Grit 320# (100pcs/box) 1.40
	T61	125mm - 6 holes, Grit 400# (100pcs/box) 1.40
	T62	125mm - 6 holes, Grit 500# (100pcs/box) 1.40
	T63	125mm - 6 holes, Grit 600# (100pcs/box) 1.40

<b>Coated C411 Velcro Disc, 125mm diameter, 8 holes</b>		
2	2 608 608 T64	125mm - 8 holes, Grit 60# (50pcs/box) 1.40
	T65	125mm - 8 holes, Grit 80# (50pcs/box) 1.40
	T66	125mm - 8 holes, Grit 100# (50pcs/box) 1.40
	T67	125mm - 8 holes, Grit 120# (50pcs/box) 1.40
	T68	125mm - 8 holes, Grit 150# (50pcs/box) 1.40
	T69	125mm - 8 holes, Grit 180# (100pcs/box) 1.40
	T70	125mm - 8 holes, Grit 220# (100pcs/box) 1.40
	T71	125mm - 8 holes, Grit 240# (100pcs/box) 1.40
	T72	125mm - 8 holes, Grit 280# (100pcs/box) 1.40
	T73	125mm - 8 holes, Grit 320# (100pcs/box) 1.40
	T74	125mm - 8 holes, Grit 400# (100pcs/box) 1.40
	T75	125mm - 8 holes, Grit 500# (100pcs/box) 1.40
	T76	125mm - 8 holes, Grit 600# (100pcs/box) 1.40

<b>125mm 8 holes velcro disc Best for wood &amp; metal (Red) -</b>		
2 608 621	545	125mm Velcro #40 (50pcs) 193.50*
	546	125mm Velcro #60 (50pcs) 193.50*
	547	125mm Velcro #80 (50pcs) 193.50*
	548	125mm Velcro #120 (50pcs) 193.50*
	549	125mm Velcro #180 (50pcs) 193.50*
	550	125mm Velcro #240 (50pcs) 193.50*
	551	125mm Velcro #320 (50pcs) 193.50*

<b>125mm 8 holes velcro disc Best for wood &amp; metal (Red)</b>		
2 608 621	577	125mm Velcro #40 (5pcs) 21.70
	578	125mm Velcro #60 (5pcs) 21.70
	579	125mm Velcro #80 (5pcs) 21.70
	580	125mm Velcro #120 (5pcs) 21.70
	581	125mm Velcro #180 (5pcs) 21.70
	582	125mm Velcro #240 (5pcs) 21.70
	583	125mm Velcro #320 (5pcs) 21.70

**Note:** \*Item marked are based on Indent Basis.

Valid in West Malaysia and while stocks last only.

# Expert for Wet + Dry

## High removal rate and consistent surface finish

► Suitable for wet and dry sanding of all car body parts.

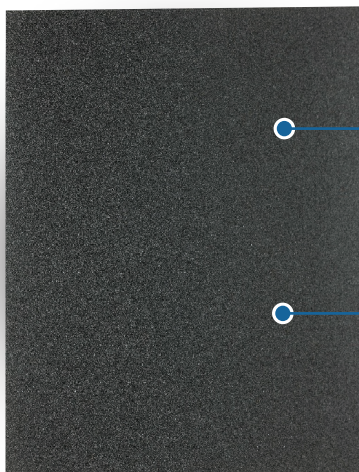

Excellent consistent surface finish due to premium silicon carbide grain.

Highly flexible for all contours and shapes thanks to water resistant latex paper.

Item	Application	Part Number	Grain/Grit Size	Size(mm)	Packaging	List Price (RM)
1	Wet & Dry	<b>2 608 621 527</b>	60	230*280	100 Pieces /Cardboard/ Shrinkpacked	<b>193.50</b>
2	Wet & Dry	<b>2 608 621 528</b>	80	230*280	100 Pieces /Cardboard/ Shrinkpacked	<b>193.50</b>
3	Wet & Dry	<b>2 608 621 529</b>	100	230*280	100 Pieces /Cardboard/ Shrinkpacked	<b>193.50</b>
4	Wet & Dry	<b>2 608 621 530</b>	120	230*280	100 Pieces /Cardboard/ Shrinkpacked	<b>193.50</b>
5	Wet & Dry	<b>2 608 621 531</b>	150	230*280	100 Pieces /Cardboard/ Shrinkpacked	<b>193.50</b>
6	Wet & Dry	<b>2 608 621 532</b>	180	230*280	100 Pieces /Cardboard/ Shrinkpacked	<b>193.50</b>
7	Wet & Dry	<b>2 608 621 533</b>	220	230*280	100 Pieces /Cardboard/ Shrinkpacked	<b>193.50</b>
8	Wet & Dry	<b>2 608 621 534</b>	240	230*280	100 Pieces /Cardboard/ Shrinkpacked	<b>193.50</b>
9	Wet & Dry	<b>2 608 621 535</b>	320	230*280	100 Pieces /Cardboard/ Shrinkpacked	<b>193.50</b>
10	Wet & Dry	<b>2 608 621 536</b>	400	230*280	100 Pieces /Cardboard/ Shrinkpacked	<b>193.50</b>
11	Wet & Dry	<b>2 608 621 537</b>	500	230*280	100 Pieces /Cardboard/ Shrinkpacked	<b>193.50</b>
12	Wet & Dry	<b>2 608 621 538</b>	600	230*280	100 Pieces /Cardboard/ Shrinkpacked	<b>193.50</b>
13	Wet & Dry	<b>2 608 621 539</b>	800	230*280	100 Pieces /Cardboard/ Shrinkpacked	<b>193.50</b>
14	Wet & Dry	<b>2 608 621 540</b>	1000	230*280	100 Pieces /Cardboard/ Shrinkpacked	<b>193.50</b>
15	Wet & Dry	<b>2 608 621 541</b>	1200	230*280	100 Pieces /Cardboard/ Shrinkpacked	<b>193.50</b>
16	Wet & Dry	<b>2 608 621 542</b>	1500	230*280	101 Pieces /Cardboard/ Shrinkpacked	<b>193.50</b>
17	Wet & Dry	<b>3 608 621 543</b>	2000	230*280	102 Pieces /Cardboard/ Shrinkpacked	<b>193.50</b>
18	Wet & Dry	<b>4 608 621 544</b>	2500	230*280	103 Pieces /Cardboard/ Shrinkpacked	<b>193.50</b>



### Storage Do's and Don'ts

Recommendation for correct storage of abrasives:

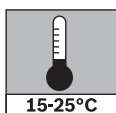

► Temperature: 15 to 25°C

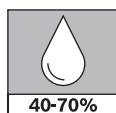

► Relative humidity: 40-70%

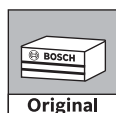

► Store in original packaging



► Never on concrete floors



► Never by an open window



► Never near to a radiator



1

2

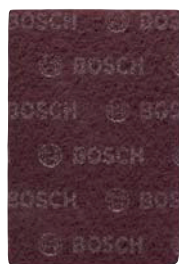

3



4



## Foam & Sponge Abrasive (hand sanding)

Part Number	<b>EXPERT</b>	Description	Packaging	List Price (RM)
<b>Combi Abrasive Sponge (Best for Flat + Edge) MOQ: 50pcs</b>				
2 608 608 223	2 608 901 168	Fine	50 pcs / box	<b>5.90/pc</b>

### Color Foam Block (Best for Flat & Edge) MOQ: 50pcs

1	2 608 608 225	2 608 901 169	Medium	50 pcs / box	<b>5.60/pc</b>
	226	170	Fine	50 pcs / box	<b>5.60/pc</b>
	228	180	Super fine	50 pcs / box	<b>5.60/pc</b>

### Color Foam Pad (Best for Edge) MOQ: 50pcs

	2 608 608 229	2 608 901 171	Medium	50 pcs / box	<b>5.25/pc</b>
2	230	172	Fine	50 pcs / box	<b>5.25/pc</b>
	231	173	Super Fine	50 pcs / box	<b>5.25/pc</b>

## Non Woven Abrasive for Metal & Inox

**MOQ: 20pcs**

	2 608 608 211	2 608 901 212	Fleece Pad - Best for Finish Coarse (Brown)	152 mm x 229 mm (20 pcs)	<b>5.60/pc</b>
		212	213	Fleece Pad - Best for Finish Bright (Black)	152 mm x 229 mm (20 pcs) <b>5.60/pc</b>
3	213		215	Fleece Pad - Best for Finish Matt (Maroon)	152 mm x 229 mm (20 pcs) <b>5.60/pc</b>
4	214		217	Fleece Pad - Expert for Finish (Green)	152 mm x 229 mm (20 pcs) <b>5.60/pc</b>

	2 608 608 215	2 608 901 222	Fleece Roll - Best for Finish Coarse	100 mm x 10 M	<b>238.50*</b>
	216	2 608 901 223	Fleece Roll - Best for Finish Bright	100 mm x 10 M	<b>238.50*</b>

**Note:** \*Items marked are based on Indent Basis.  
Valid in West Malaysia and while stocks last only.



1



3



2



4



## Multi Sander Accessories

Part Number	EXPERT	Description	List Price (RM)
<b>For Model GEX 150 AC</b>			
<b>Sanding Paper for Wood and Metal (5 piece pack)</b>			
1	2 608 605 086	Sanding Paper x 150 mm (G 60)	27.50*
	087	Sanding Paper x 150 mm (G 80)	25.70*
2	3 608 610 000	Lambswool Bonnet - 2 pcs per pack (160 mm)	94.00*
3	3 608 613 000	Polishing Sponge (160 mm)	55.50*

### For Model 125-1A/AE

#### Sanding Paper for Wood and Metal (5 piece pack)

2 608 605 058	2 608 900 794	Sanding Paper 115 mm (G 40)	23.00
059	795	Sanding Paper 115 mm (G 60)	21.50
060	796	Sanding Paper 115 mm (G 80)	19.40
061	797	Sanding Paper 115 mm (G 120)	19.40
062	798	Sanding Paper 115 mm (G 180)	19.40
063	799	Sanding Paper 115 mm (G 240)	19.40
064	800	Sanding Paper 115 mm (G 320)	19.40
065	801	Sanding Paper 115 mm (G 400)	19.40
066	802	Sanding Paper 115 mm (G 60 / 120 / 240 - 2 pcs each)	23.00

### For Model GEX 125-1 A/AE (2008 Model)

2 608 000 349	Rubber Pad, standard (GEX 125-1 A/AE, 2008 model)	81.50
---------------	---	-------

## Bench Grinder Accessories

### For Model GBG 60-20

2 608 600 111	Grinding Wheel 200 x 25 x 32 mm (Fine / Grit 36)	82.50
4 2 608 600 112	Grinding Wheel 200 x 25 x 32 mm (Fine / Grit 60)	82.50

## Belt Sander Accessories

### For Model GBS 75A

#### Sanding Belt for Wood and Metal (3 piece pack)

2 608 606 069	Sanding Belt 75 x 533 mm (G 40)	31.90
070	Sanding Belt 75 x 533 mm (G 60)	31.90
071	Sanding Belt 75 x 533 mm (G 80)	31.90
072	Sanding Belt 75 x 533 mm (G 100)	31.90
073	Sanding Belt 75 x 533 mm (G 150)	31.90
074	Sanding Belt 75 x 533 mm (G 220)	31.90
076	Sanding Belt 75 x 533 mm (G 320)	31.90

**Note:** \*Items marked are based on Indent Basis.

Valid in West Malaysia and while stocks last only.



# TCT Annular Cutter

## The high efficiency solution for metal drilling

### High Efficiency

- Optimized tip geometry, with **outer-intermediate-inner tip combination** achieves extra high working rate and slim chips. Drilling is fast and has lower risk to get jammed

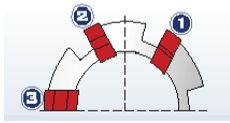

### Universal shank

Standard 19mm universal shank fit to magnetic drill with universal/Weldon interface

### Extended lifetime

- Industrial level carbide with 8% Cobalt alloyed offers a teeth hardness up to **1600 HV10**, highly resistant to wear and heat. A medium size cutter can drill up to 1000+ holes \*

\* In Bosch standard test conditions

## TCT Annular Cutter

Part Number	Description	Pin Reference	List Price (RM)
<b>2608577483</b>	14x35mm	PL6035	<b>195.00</b>
<b>484</b>	16x35mm	PL6035	<b>195.00</b>
<b>485</b>	18x35mm	PL8035	<b>195.00</b>
<b>486</b>	20x35mm	PL8035	<b>195.00</b>
<b>487</b>	22x35mm	PL8035	<b>206.50</b>
<b>488</b>	24x35mm	PL8035	<b>206.50</b>
<b>489</b>	26x35mm	PL8035	<b>218.00</b>
<b>490</b>	28x35mm	PL8035	<b>218.00</b>
<b>491</b>	30x35mm	PL8035	<b>218.00</b>
<b>492</b>	32x35mm	PL8035	<b>252.50</b>
<b>493</b>	35x35mm	PL8035	<b>252.50</b>
<b>494</b>	40x35mm	PL8035	<b>275.50</b>
<b>507</b>	PIN, PL6035 (6.34X90mm)		<b>27.60</b>
<b>508</b>	PIN, PL8035 (8x90mm)		<b>27.60</b>



1



Keyless Chuck

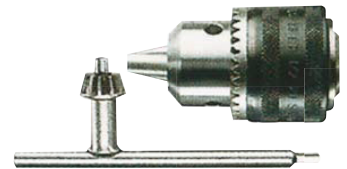

Key Chuck

## Multi Sander Accessories

<b>1</b>	<b>2 608 601 062</b>	Rubber Pad, standard (125 mm)	<b>54.00</b>
	<b>063</b>	Rubber Pad, soft (125 mm)	<b>53.00</b>

## Key Chuck & Keyless Chuck

### Keyless Chuck

<b>2 608 572 217</b>	<b>3/8" - 24</b>	3/8 (10 mm)	<b>37.30</b>
<b>075</b>	<b>1/4" - 6K for GDR</b>	3/8 (10 mm)	<b>119.50</b>

### Key Chuck

<b>2 608 571 078</b>	<b>3/8" - 24</b>	3/8 (10 mm)	<b>32.80</b>
<b>079</b>	<b>1/2" - 13</b>	1/2 (13 mm)	<b>35.60</b>

## Chuck Key

<b>1</b>	<b>607 950 042</b>	Pairing with chuck 1 608 571 066 / 1 608 571 058	<b>16.60</b>
	<b>028</b>	Pairing with chuck 2 608 571 010	<b>15.60</b>
	<b>045</b>	Pairing with chuck 1 608 571 048	<b>15.60</b>

**Note:** \*Items marked are based on **Indent Basis**.

Valid in West Malaysia and while stocks last only.

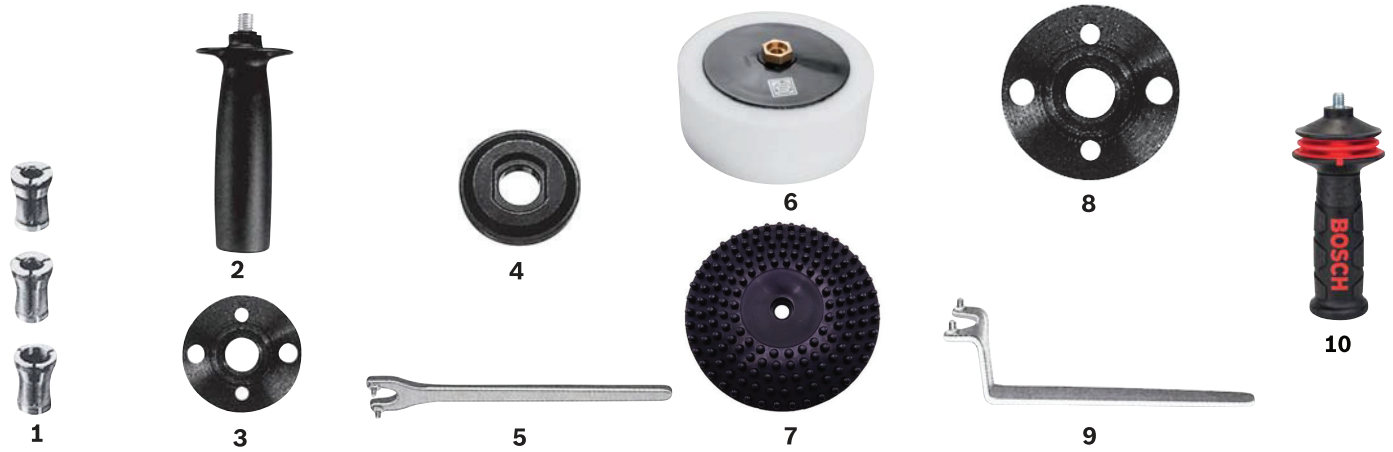

## Straight Grinder, Trimmer and Router Accessories

Part Number	<b>EXPERT</b>	Description	List Price (RM)
<b>For Model GGS 3000L, GGS 5000L, GGS 28 LC, GGS 28 C</b>			
1	2 608 570 008	Collet 3.0 mm	42.00
	047	Collet 6.0 mm	37.30
	049	Collet 8.0 mm	37.30*

## Angle Grinder Accessories

<b>For Model GWS 20-180, GWS 20-180 S &amp; GWS 20-231</b>			
2	2 602 025 075	Handle (M14) - for all 2 Hand Grinder	13.80
3	1 603 340 040	Round Nut	15.60
4	1 605 703 099	Flange	15.60
5	1 607 950 048	Pin Spanner	16.10

## Polisher & Angle Grinder Accessories

<b>For Model GPO 12 CE Polisher</b>			
6	1 608 613 013	Polishing Sponge (160 mm)	203.00*
	1 608 610 000	Lambswool Bonnet (180 mm)	111.00*
	2 608 601 209	180mm rubber pad (M14)	61.00
7	9 618 086 718	Buffing Disc (Under ASA)	45.00
<b>For Model GWS 6-100, GWS 7-100, GWS 7-100 T, GWS 7-100 ET, GWS 8-100 C &amp; GWS 8-100 CE</b>			
<b>Handle Antivibration (M10)</b>			
8	2 603 340 018	Round Nut (M 10)	25.40
9	1 607 950 040	Pin Spanner	17.30
	1 602 025 024	Handle (M 10)	10.95
10	2 602 025 171	2 608 900 000 Vibration Control Hander	69.00

**Note:** \*Items marked are based on Indent Basis.  
Valid in West Malaysia and while stocks last only.



## Sanding & Polishing for Drill

Part Number	Description	List Price (RM)
<b>1</b> 1 609 200 240	5" Rubber Backing Pad	<b>25.90</b>
<b>2</b> 245	5" Lambswool Bonnet	<b>28.60</b>
<b>3</b> 250	5" Polishing Sponge (Foam With rubber backing pad)	<b>38.20</b>
<b>160</b>	5" Sanding Paper - Coarse / Grit 40 (5 pcs pack)	<b>7.45*</b>
<b>161</b>	5" Sanding Paper - Coarse / Grit 60 (5 pcs pack)	<b>7.45*</b>
<b>162</b>	5" Sanding Paper - Medium / Grit 80 (5 pcs pack)	<b>7.45*</b>
<b>163</b>	5" Sanding Paper - Fine / Grit 120 (5 pcs pack)	<b>7.45*</b>
<b>164</b>	5" Sanding Paper - Very Fine / Grit 180 (5 pcs pack)	<b>7.45*</b>
<b>165</b>	5" Sanding Paper - Grit 40, 60, 80, 120 & 180 (2 pcs each) (10 pcs pack)	<b>13.40*</b>
<b>4</b> 287	Flap Wheel 50 x 20 mm (Grit 60)	<b>42.60</b>

## De-rusting Accessories for Drill

<b>5</b> 1 609 200 269	Pencil Brush - Crimped Wire (0.3 x 25 mm)	<b>25.40*</b>
<b>6</b> 270	Wire Cup Brush - Crimped Wire (0.3 x 70 mm)	<b>29.10</b>
<b>271</b>	Wire Cup Brush - Crimped Wire (0.2 x 70 mm)	<b>29.10</b>
<b>2 608 622 022</b>	Wire Cup Brush - Crimped Wire (0.2 x 50 mm)	<b>15.80*</b>
<b>7</b> 1 609 200 273	Wire Wheel - Crimped Wire (0.3 x 100 mm)	<b>28.00</b>
<b>8</b> 2 608 601 762	Diamond Cupwheel Expert for Concrete Long Life (125 x 22.23 x 5 mm)	<b>119.50</b>
<b>763</b>	Diamond Cupwheel Expert for Concrete High Speed (125 x 22.23 x 5 mm)	<b>119.50</b>

## Shaping Accessories for Drill

<b>9</b> 1 609 200 307	Set (3 pcs) of Freehand Router Bits	<b>48.50</b>
<b>10</b> 314	Set (4 pcs) of Freehand Router Bits	<b>76.30</b>
<b>11</b> 286	Set (5 pcs) of Mounted Grinding Stone	<b>54.70*</b>
<b>12</b> 243	Hole Saw (8 pcs set) - 25 mm to 68 mm	<b>73.00</b>
<b>244</b>	Hole Saw 80 mm	<b>61.20*</b>

**Note:** \*Items marked are based on **Indent Basis**.  
Valid in West Malaysia and while stocks last only.

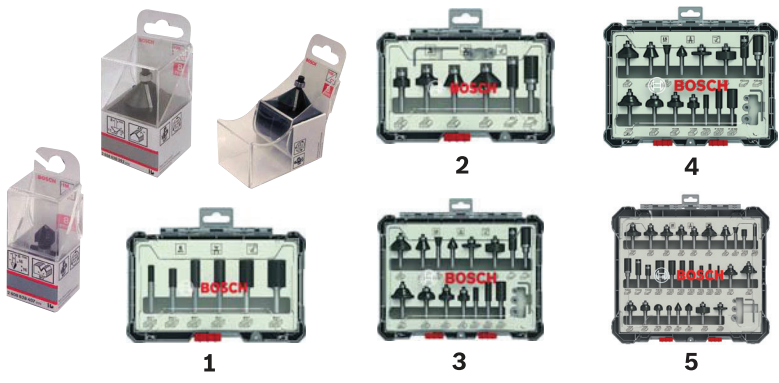
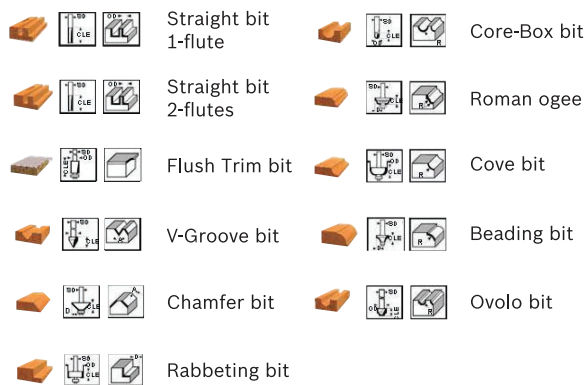

## Router Bit (Carbide-Tipped) - 1/4" Shank

Item	Part Number	Description	Specification (1/4" shank)	List Price (RM)
	<b>2 608 628 427</b>	Straight bit, 1-flute	1/8 x 5/16 x 2	<b>31.00</b>
	<b>428</b>	Straight bit, 1-flute	3/16 x 1/2 /2	<b>32.10</b>
	<b>411</b>	Straight bit, 2-flutes	1/4 x 5/8 x 1 7/8	<b>37.30</b>
	<b>429</b>	Straight bit, 2-flutes	5/16 x 25/32 x 2	<b>34.50</b>
	<b>412</b>	Straight bit, 2-flutes	3/8 x 25/32 x 2	<b>42.00</b>
	<b>413</b>	Straight bit, 2-flutes	1/2 x 25/32 x 2	<b>47.00</b>
	<b>414</b>	Straight bit, 2-flutes	3/4 x 25/32 x 2	<b>51.80</b>
	<b>635</b>	Flush Trim bit (ball bearing)	1/4 x 1/2 x 2 1/8	<b>47.00</b>
	<b>636</b>	Flush Trim bit (ball bearing)	3/8 x 9/16 x 2 3/16	<b>48.30</b>
	<b>637</b>	Flush Trim bit (ball bearing)	1/2 x 1/2 x 3 3/16	<b>50.00</b>
	<b>630</b>	V-Groove bit	1/4 x 5/16 x 90° x 1 9/16	<b>33.30</b>
	<b>631</b>	V-Groove bit	3/8 x 1/2 x 90° x 1 3/4	<b>34.00</b>
	<b>415</b>	V-Groove bit	1/2 x 1/2 x 90° x 1 3/4	<b>35.60</b>
	<b>416</b>	Chamfer bit (ball bearing)	7/16 x 19/32 x 45° x 2 3/16	<b>66.00</b>
	<b>417</b>	Rabbeting bit (ball bearing)	1 x 1/2 x 1/4 x 2 1/8	<b>70.60</b>
	<b>425</b>	Core-Box bit	1/4 x 3/8 x R1/8 x 1 9/16	<b>32.80</b>
	<b>632</b>	Core-Box bit	3/8 x 3/8 x R3/16 x 1 9/16	<b>35.60</b>
	<b>418</b>	Core-Box bit	1/2 x 3/8 x R1/4 x 1 9/16	<b>39.00</b>
	<b>633</b>	Core-Box bit	5/8 x 1/2 x R5/16 x 1 3/4	<b>45.50*</b>
	<b>634</b>	Core-Box bit	1 x 5/8 x R1/2 x 2 1/4	<b>51.80*</b>
	<b>419</b>	Roman-Ogee (ball bearing)	5/6 x 1/2 x R4 x 2 1/8	<b>58.00</b>
	<b>420</b>	Cove bit (ball bearing)	1 x 1/2 x R1/4 x 2 1/8	<b>56.30</b>
	<b>421</b>	Beading bit (ball bearing)	1/4 x 17/32 x R1/4 x 2 3/16	<b>65.50</b>
	<b>422</b>	Beading bit (ball bearing)	3/8 x 21/32 / R3/8 x 2 5/16	<b>70.60</b>
	<b>423</b>	Beading bit (ball bearing)	1/2 x 3/4 x R1/2 x 2 7/16	<b>77.00</b>
	<b>424</b>	Ovolo bit	1 x 9/16 x R1/4 x 1 13/16	<b>64.30*</b>
<b>1</b>	<b>2 607 017 467</b>	Straight Bit Set 1/4 Shank (6pcs)		<b>207.00</b>
<b>2</b>	<b>470</b>	Trim & Edging Set 1/4 Shank (6pcs)		<b>224.00</b>
<b>3</b>	<b>473</b>	Mixed Bit Set 1/4 Shank (15pcs)		<b>493.00</b>
<b>4</b>	<b>471</b>	Mixed Bit Set 6mm Shank ( 15pcs)		<b>612.00</b>
	<b>472</b>	Mixed Bit Set 8mm Shank ( 15pcs)		<b>612.00</b>
	<b>474</b>	Mixed Router Bit Sets 6mm Shank (30 pcs)		<b>1,092.00</b>
<b>5</b>	<b>475</b>	Mixed Router Bit Sets 8mm Shank (30 pcs)		<b>1,092.00</b>
	<b>476</b>	Mixed Router Bit Sets 1/4" mm Shank (30 pcs)		<b>1,092.00</b>

**Note:** \*Items marked are based on **Indent Basis**.  
Valid in West Malaysia and while stocks last only.



1



3



2



4



5

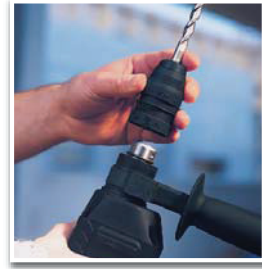

## Planer Accessories

Part Number	Description	List Price (RM)
<b>For Model GHO 6500 &amp; GH 10-82</b>		
2 607 000 193	Makita type, HSS Blade (x 2) (GHO 10-82)	96.00
2 608 838 999	Reversible Tungston Carbide Planer Blade	69.00

## Other Tools

	2 602 025 063	Auxilliary Handle for GSH 5CE for 0611 313 706	156.00*
	076	Auxilliary Handle for GSH 11E	172.50*
	1 602 025 097	Auxilliary Handle for GSH 5CE for 0611 321 040 (Under ASA)	107.50
	1 612 025 055	Auxilliary Handle for GBH 5-40 DCR for 0611 264 070 (Under ASA)	126.00
<b>For Model GBH 2 -24 DRE / DFR, GBH 4-32-DFE, GBH 2-26 DRE/DFR</b>			
1	1 612 025 032	Auxilliary Handle for GBH 2SE. GBH 2 - 24	69.50 *
2	1 618 571 014	SDS PlusAdapter with Chuck (2.5 -13mm)	228.50 *
3	1 617 000 132	SDS Plus Adapter	45.00
4	2 608 572 059	SDS Plus quick change Chuck for GBH 4-32-DFE	209.00
5	112	SDS Plus quick change Chuck for GBH 2 - 24 DFR	196.00
	213	SDS Plus quick change Chuck for GBH 2 - 26 DFR/ GBH 4-32 DFR*	196.00
	2 608 572 212	Keyless Chuck ( GHB 2 - 26 ) DFR	285.50
	2 608 572 253	13 mm Chuck with Key for 2kg Hammer ( 20 RNF )	36.80

## Foam Rubber Cutter Accessories

**For Model 1575, GSG 300 & GSG 9.6 V**

	2 607 018 011	Sawblade 200 mm (8.0") T43A	116.00
	012	Sawblade 300 mm (11 ¾") T43C	176.50
	2 608 135 021	Guide 200 mm (8.0") T42B	268.50
	022	Guide 300 mm (11 ¾") T42C	256.00

**Note:** \*Items marked are based on Indent Basis.  
Valid in West Malaysia and while stocks last only.



## Shear Accessories (Metal)

Part Number	Description	List Price (RM)
<b>For Model GSC 2.8</b>		
1	2 607 010 025 Upper and Lower Blade Set	128.00

## Nibbler Accessories (Metal)

<b>For Model GNA 2.1</b>		
2	2 608 639 900 Universal Die-holder (Original with Tool)	269.50*
3	021 Die-holder for corrugated materials	270.50*
4	013 Straight & Curve Cutting Punch (Original with Tool)	100.50
5	022 Cutting Punch for corrugated materials	123.00*
6	902 Cutting Punch and Die-holder Set for corrugated materials	353.00*

## Vacuum Cleaner Accessories

<b>For Model GAS15/15PS</b>		
Part number	Description	List Price (RM)
<b>Anti-Static Hose</b>		
2 608 000 570	3 meter anti-static hose	665.00*
2 607 002 164	5 meter anti-static hose	1,008.50*
<b>Filter</b>		
2 607 432 024	Bellows filter	188.00*
<b>Nozzle (35 mm Fitting)</b>		
1 609 390 481	Small Round Brush	24.80
2 607 000 166	Small Floor Nozzle	51.80*
170	Coarse Dirt Nozzle	57.50*
1 609 390 478	Multi-purpose Nozzle (with 3 inserts)	126.50
2 607 000 165	Crevice Nozzle	35.10
1 609 201 229	Rubber Nozzle	54.00*
2608 000 573	Pipe Elbow	64.30*
585	Tool Sleeve	115.00*
2 607 002 149	Air Hose Ø 35mm-3m	124.50
150	Air Hose Ø 35mm-5m	125.00
2 605 411 150	Dusty Bag 5 pcs	132.50
1 609 203 B92	Suction Pipe (Under ASA)	36.00
2 607 000 162	Suction Pipe Ø 35mm 0.5m	63.70

**Note:** \*Items marked are based on Indent Basis.

Valid in West Malaysia and while stocks last only.



1



2



3



4



5

## Hot Air Gun Accessories

Part Number	Description	List Price (RM)
-------------	-------------	-----------------

**For Model GHG 600 CE, GHG 650 LCE, GHG 600 -3, GHG 600 DCE, GHG 18-60, CHG 20-63**

	<b>1 609 201 795</b>	Surface Nozzle (50 mm)	<b>50.50*</b>
<b>1</b>	<b>1 609 390 453</b>	Reflector Nozzle	<b>58.50</b>

**Only for GHG 20-63**

<b>2</b>	<b>1 609 201 647</b>	Reduction Nozzle (14 mm)	<b>55.10</b>
	<b>797</b>	Reduction Nozzle (9 mm)	<b>59.20</b>
<b>3</b>	<b>798</b>	Welding / Rods Nozzle - <i>In conjunction with 1 609 201 797</i>	<b>78.00</b>
<b>4</b>	<b>800</b>	Cutting Nozzle - <i>In conjunction with 1 609 201 797</i>	<b>62.00*</b>
<b>5</b>	<b>801</b>	Welding / Wire Nozzle - <i>In conjunction with 1 609 201 797</i>	<b>55.00*</b>

**Note:** \*Items marked are based on Indent Basis.  
Valid in West Malaysia and while stocks last only.

## Rotary Hammer

Service Pack	Part Number	List Price (RM)
GBH 3-28 E	1 617 000 383	45.00
GBH 4-32 DFR	1 617 000 897	100.00
GBH 5-38 D	1 617 000 A16	109.00
GBH 5-40 D	1 619 P10 768	128.00
GBH 7-45 DE	1 617 000 182	128.00
GBH 7-46 DE (with Grease Tube)	1 617 000 465	188.00
GBH 8-45 DV	1 610 103 026	135.00

## Demolition Hammer

GSH 388	1 617 000 A15	84.00
GSH 5	1 619 P07 788	69.00
GSH 5X	1 619 P09 706	64.00
GSH 5 E	1 617 000 431	74.00
GSH 5 CE	1 617 000 708	136.00
GSH 11 E (with Grease tube)	1 617 000 190	176.00
GSH 11 VC	1 617 000 758	156.00
GSH 16-30 (with Grease tube)	1 617 000 702	199.00
GSH 27 (with Grease tube)	1 617 000 426	195.00
GSH 27 VC (with Grease tube)	1 617 000 732	281.00

## Grease for Hammer

Part Number	Packing	List Price (RM)
1 605 430 003 (Angle Grinder)	225ml	103.00
1 615 430 005 (2kg & 3kg Hammer)	45ml	27.00
1 615 430 001 (2kg & 3kg Hammer)	225ml	57.00
1 615 430 007 (2kg & 3kg Hammer)	1000ml	187.00
1 615 430 014 (≥5kg Hammer)	45ml	31.00
1 615 430 015 (≥5kg Hammer)	225ml	91.00
1 615 430 016 (≥5kg Hammer)	1000ml	217.00

## Oil for Hammer

Model	Part Number	Packing	List Price (RM)
GBH 3-28 E	1 615 430 019	1 litre	160.00
GSH 388 & GBH 5-38	1 615 430 019	1 litre	160.00



# Bosch Range Spare Parts

Model	Part Number	Motor	List Price(RM)	Charger	List Price (RM)	Batt.Pack	List Price(RM)	Switch/Module	List Price(RM)
GSB 180-Li	3 601 JF8 3K0	1 607 022 66N	59.00	2 607 226 283	95.00	1 617 S00 T1Z	324.00	2 607 202 330	70.00
GSR 180-Li	3 601 JF8 1K0	1 607 022 66N	59.00	2 607 226 283	95.00	1 617 S00 T1Z	324.00	2 607 202 330	70.00
GSR 120-Li	3 601 JF7 0L0	1 607 000 C5K	58.00	1 600 A00 HR3	64.00	1 607 A35 04A	156.00	2 609 125 169	64.00
GSB 120-Li	3 601 JF3 0L3	2 609 199 428	69.00	1 600 A00 HR3	64.00	1 607 A35 04A	156.00	2 609 125 169	64.00
GSR 120-Li Gen II	3 601 JG8 080	1 607 000 D7K	51.00	1 600 A00 HR3	64.00	1 607 A35 0DY	143.00	2 607 202 520	74.00
GSB 120-Li Gen II	3 601 JG8 180	1 607 000 D7K	51.00	1 600 A00 HR3	64.00	1 607 A35 0DY	143.00	2 607 202 520	74.00
GDR 120-Li	3 601 JF0 0L1	1 600 A00 PE3	46.00	1 600 A00 HR3	64.00	1 607 A35 04A	156.00	2 607 202 312	67.00
Pro Pruner	3 601 JK1 0L0	1 619 P16 098 (Motor assembly)	208.37	1 600 A00 HR3	64.00	1 607 A35 04A	156.00	1 619 P15 722	159.87
GSR 185-Li	3 601 JK3 080	1 607 000 EC2 (rotor)	41.00	1 600 A01 B92	155.00	1 600 A00 1CG	260.00	2 607 202 513	138.20
GSB 185-Li	3 601 JK3 180	1 607 000 EC2 (rotor)"	41.00	1 600 A01 B92	155.00	1 600 A00 1CG	260.00	2 607 202 513	138.20
GDS 250-Li	3 601 JG6 1K0	2 609 120 731	140.00	1 600 A00 16Y	165.00	1 600 A00 163	385.00	2 609 199 892	100.00
GDR 180-Li	3 601 JG5 121	1 607 022 67M	201.00	1 600 A01 B92	155.00	1 600 A00 1CG	260.00	2 607 202 399	156.00
GBH 180-Li	3 611 J11 1K0	1 619 P15 614	61.00	1 600 A01 B92	155.00	1 600 A00 1CG	260.00	1 600 A02 0T1	119.00
GBH 187 Li	3 611 J23 181	1 619 P17 162 (rotor)	126.00	1 600 A01 B92	155.00	1 600 A00 163	385.00	1 619 P16 921	71.00
GWS 180-Li	3 601 JH9 0K0	1 619 P15 044	40.00	1 600 A01 B92	155.00	1 600 A00 1CG	260.00	1 600 A01 NC3	316.00
GDX 180-Li	3 601 JG5 2L1	1 607 022 67M	201.00	1 600 A01 B92	155.00	1 600 A00 1CG	260.00	2 607 202 399	156.00
GLI 180-Li	3 601 DA1 1L0	-----	-----	1 600 A01 B92	155.00	1 600 A00 1CG	260.00	-----	-----
GST 185-Li solo	3 601 EB3 020	1 619 P16 471	88.00	1 600 A01 B92	155.00	1 600 A00 163	385.00	1 619 P16 218	162.00
GKS 185-Li solo	3 601 FC1 2E0	1 619 P16 617	89.00	1 600 A01 B92	155.00	1 600 A00 1CG	260.00	1 619 P16 372	221.00
GEX 185-Li solo	3 601 CA5 080	1 619 PB8 570	62.00	1 600 A01 B92	155.00	1 600 A00 163	385.00	1 619 PB6 097	138.00
GTB 185-Li solo	3 601 JK7 020	1 607 000 E6G	80.00	1 600 A01 B92	155.00	1 600 A00 1CG	260.00	2 607 202 902	47.00
GSA 185-Li solo	3 601 FC0 0L0	1 619 PB7 610 (Armature assembly)	227.00	1 600 A01 9S7	555.00	1 600 A01 93N	545.00	1 619 PB7 518	267.00
GOP 185-Li Solo	3 601 HG2 020	1 619 PB9 377	94.00	1 600 A01 B92	155.00	1 600 A00 163	385.00	1 619 PB6 095	212.00

Model	Part Number	Armature	List Price	Stator	List Price	Carbon Brush	List Price	Switch	List Price
GBH 180-Li	3 611 J11 0K0	1 619 P14 346	59.00	1 619 P13 742	30.00	1 619 P14 345	17.00	1 600 A00 F9H	119.00
GKS 7000	3 601 F76 0L0	1 619 P10 062	116.00	1 619 P08 314	98.00	1 619 P10 063	15.00	1 619 P09 971	20.00
GSH 500	3 611 C38 5L0	1 619 P12 719	106.00	1 619 P14 878	64.00	1 617 014 138	17.00	1 619 P09 019	27.00
GHO 6500	3 601 E96 0L0	1 619 PA7 993	58.00	1 619 PA7 991	46.00	2 609 120 398	23.00	1 619 PA7 983	20.00
GWS 060	3 601 C75 6L0	1 619 P01 844	28.00	1 619 P12 316	22.00	1 619 P07 571	8.00	1 607 200 179	16.00
GBM 320	3 601 AA4 5L0	1 619 PA5 010	40.00	1 619 PA4 180	29.00	1 619 PA4 619	8.00	1 619 PA4 597	20.00
GBM 350	3 601 AA9 5L0	1 619 P20 267	36.00	1 619 P20 093	29.00	1 619 P20 086	8.00	2 607 200 623	18.00
GBM 400	3 601 AC1 0L0	1 619 PB8 917	33.00	-----	-----	-----	-----	1 619 PB8 886	19.00
GDM 121	3 601 C95 0L0	1 619 PA9 243	58.00	1 619 PA7 559	37.00	1 619 PA4 025	8.00	1 619 PA7 561	5.00
GCO 200	3 601 M37 0L0	1 609 B03 639	106.00	1 609 B00 135	74.00	1 607 014 171	16.00	1 609 B03 606	19.00
GCO 220	3 601 M37 3P0	1 609 B03 639	106.00	1 609 B00 135	74.00	1 607 014 171	16.00	1 609 B03 606	19.00
GSS 2300	3 601 B98 0L0	1 619 PA7 629	52.00	1 619 PA7 627	46.00	1 619 PA7 635	15.00	1 619 PA7 631	15.00
GSS 140	3 601 BA8 0L0	1 604 010 B9N	40.00	1 604 220 577	26.00	1 619 PB3 111	6.00	1 607 200 35P	12.00
GDC 140	3 601 CA0 0L0	1 619 P20 452	94.00	1 619 P20 361	67.00	1 619 P20 377	9.00	1 619 PB5 623	15.00
GSH 500 Gen II	3 611 C38 6L0	1 619 P15 121	106.00	1 619 P14 878	64.00	1 617 014 138	17.00	1 619 P09 019	27.00
GKS 140	3 601 FB3 0L1	1 604 010 B9J	97.00	1 607 000 D17	52.00	1 619 PB4 042	21.00	1 619 PB3 945	13.00
GBH 220	3 611 BA6 0L0	1 619 P16 276	76.00	1 616 B10 269	32.00	1617 000 525	13.00	1 607 200 372	40.00
GAC 250	3 601 BB6 0K0	1 619 PB9 760	120.00	-----	-----	-----	-----	1 619 PB6 695	16.00

# Spare Parts Price List

## Drill

Model	Part Number	Armature	List Price (RM)	Stator	List Price (RM)	Carbon	List Price (RM)	Switch	List Price (RM)
<b>GBM 6 RE</b>	<b>0 601 145 506</b>	2 609 199 014	<b>135.00</b>	2 604 220 640	<b>57.50</b>	1 607 031 239	<b>17.00</b>	2 607 200 398	<b>81.00</b>
<b>GBM 6 RE</b>	<b>3 601 D72 5L0</b>	2 609 120 337	<b>81.00</b>	2 609 120 279	<b>42.00</b>	2 610 391 290	<b>19.00</b>	2 607 200 623	<b>18.00</b>
<b>GBM 10</b>	<b>0 601 135 042</b>	2 604 010 780	<b>132.00</b>	2 604 220 392	<b>51.00</b>	2 604 321 915	<b>13.00</b>	2 607 200 260	<b>28.00</b>
<b>GBM 10 RE</b>	<b>0 601 135 542</b>	2 604 010 707	<b>107.00</b>	2 604 220 392	<b>51.00</b>	2 604 321 911	<b>19.00</b>	2 607 200 357	<b>117.00</b>
<b>GBM 10 RE</b>	<b>3 601 D73 5L0</b>	2 609 120 338	<b>63.00</b>	2 609 120 296	<b>42.00</b>	2 610 391 290	<b>19.00</b>	2 607 200 623	<b>18.00</b>
<b>GBM 10 RE</b>	<b>3 601 D73 6L0</b>	2 609 120 338	<b>63.00</b>	2 609 120 296	<b>42.00</b>	2 610 391 290	<b>19.00</b>	2 607 200 623	<b>18.00</b>
<b>GBM 320</b>	<b>3 601 AA4 5L0</b>	1 619 PA5 010	<b>40.00</b>	1 619 PA4 180	<b>29.00</b>	1 619 PA4 619	<b>8.00</b>	1 619 PA4 597	<b>20.00</b>
<b>GBM 350</b>	<b>3 601 AA9 5L0</b>	1 619 P20 267	<b>36.00</b>	1 619 P20 093	<b>29.00</b>	1 619 P20 086	<b>8.00</b>	2 607 200 623	<b>18.00</b>
<b>GBM 400</b>	<b>3 601 AC1 0L0</b>	1 619 PB8 917(Armature set )	<b>33.00</b>	1 619 PB8 884	<b>26.00</b>	1 619 PB8 919	<b>3.00</b>	1 619 PB8 886	<b>19.00</b>
<b>GBM 13-2</b>	<b>0 601 169 006</b>	2 604 010 575	<b>176.00</b>	2 604 220 429	<b>89.00</b>	1 607 031 222	<b>19.00</b>	2 607 200 365	<b>28.00</b>
<b>GBM 13 RE</b>	<b>3 601 D77 5L0</b>	2 609 120 339	<b>93.00</b>	2 604 220 718	<b>44.00</b>	2 610 391 290	<b>19.00</b>	2 607 200 623	<b>18.00</b>
<b>GBM 13 HRE</b>	<b>0 601 023 703</b>	2 604 010 803	<b>176.00</b>	2 604 220 392	<b>51.00</b>	1 607 031 222	<b>19.00</b>	2 607 200 357	<b>117.00</b>
<b>GBM 13 HRE</b>	<b>0 601 049 603</b>	2 604 011 900	<b>176.00</b>	2 604 220 702	<b>74.00</b>	1 607 031 222	<b>19.00</b>	2 607 200 920	<b>67.00</b>
<b>GBM 50-2</b>	<b>3 601 AB4 0L0</b>	1 619 PB3 666	<b>228.00</b>	1 619 PB4 201	<b>190.00</b>	1 619 PB4 295	<b>27.00</b>	1 619 PB4 119	<b>675.00</b>
<b>0.5 - 6.5 mm Drill Chuck only</b>		1 619 PA4 607	<b>20.00</b>						
<b>0.5 - 6.5 mm Key</b>		1 619 PA4 608	<b>3.00</b>						
<b>1.0 - 10 mm Drill Chuck with Key</b>		1 608 571 079	<b>37.00</b>						
<b>1.5 - 13 mm Drill Chuk with Key</b>		2 609 000 990	<b>52.00</b>						

Valid in West Malaysia and while stocks last only.

## Impact Drill

Model	Part Number	Armature	List Price (RM)	Stator	List Price (RM)	Carbon	List Price (RM)	Switch	List Price (RM)
<b>GSB 10 RE</b>	<b>3 601 B16 1L0</b>	2 609 120 232	<b>108.00</b>	2 604 220 718	<b>44.00</b>	2 610 391 290	<b>19.00</b>	2 607 200 567	<b>72.00</b>
<b>GSB 10 RE</b>	<b>3 601 B16 1L1</b>	2 609 120 232	<b>108.00</b>	2 604 220 718	<b>44.00</b>	2 610 391 290	<b>19.00</b>	2 607 200 623	<b>18.00</b>
<b>GSB 550 RE</b>	<b>0 601 14D 706</b>	2 604 011 084	<b>110.00</b>	2 604 220 562	<b>55.00</b>	2 604 321 917	<b>12.00</b>	1 607 200 172	<b>82.00</b>
<b>GSB 13 RE</b>	<b>3 601 B17 1L0</b>	2 609 120 232	<b>108.00</b>	2 604 220 718	<b>44.00</b>	2 610 391 290	<b>19.00</b>	2 607 200 567	<b>72.00</b>
<b>GSB 13 RE</b>	<b>3 601 B17 1L1</b>	2 609 120 232	<b>108.00</b>	2 604 220 718	<b>44.00</b>	2 610 391 290	<b>19.00</b>	2 607 200 623	<b>18.00</b>
<b>GSB 13 RE</b>	<b>3 601 B27 1L0</b>	2 609 199 667	<b>90.00</b>	2 609 120 588	<b>46.00</b>	2 610 391 290	<b>19.00</b>	2 607 200 623	<b>18.00</b>
<b>GSB 18-2</b>	<b>0 601 180 042</b>	2 604 010 524	<b>219.00</b>	1 604 220 254	<b>89.00</b>	1 607 031 222	<b>19.00</b>	2 607 200 260	<b>28.00</b>
<b>GSB 18-2</b>	<b>0 601 185 060</b>	2 604 010 744	<b>134.00</b>	1 604 220 254	<b>89.00</b>	1 607 031 222	<b>19.00</b>	2 607 200 365	<b>28.00</b>
<b>GSB 16 RE</b>	<b>0 601 140 706</b>	2 604 011 140	<b>150.00</b>	2 604 220 430	<b>94.00</b>	2 604 321 913	<b>15.00</b>	2 607 200 209	<b>108.00</b>
<b>GSB 16 RE</b>	<b>0 601 140 766</b>	2 604 011 140	<b>150.00</b>	2 604 220 430	<b>94.00</b>	2 604 321 913	<b>15.00</b>	2 607 200 209	<b>108.00</b>
<b>GSB 16 RE</b>	<b>3 601 B18 1L0</b>	2 609 120 235	<b>117.00</b>	2 604 220 647	<b>54.00</b>	2 607 014 013	<b>20.00</b>	1 607 200 270	<b>42.00</b>
<b>GSB 16 RE</b>	<b>3 601 B28 1L0</b>	2 609 199 668	<b>106.00</b>	2 609 120 591	<b>53.00</b>	2 610 391 290	<b>19.00</b>	1 607 200 270	<b>42.00</b>
<b>GSB 20-2</b>	<b>0 601 184 042</b>	2 604 010 744	<b>134.00</b>	2 604 220 429	<b>89.00</b>	1 607 031 222	<b>19.00</b>	2 607 200 365	<b>28.00</b>
<b>GSB 20-2</b>	<b>0 601 184 206</b>	1 619 P00 491	<b>126.00</b>	1 604 220 254	<b>89.00</b>	1 607 031 222	<b>19.00</b>	2 607 200 260	<b>28.00</b>
<b>GSB 20-2 RE</b>	<b>0 601 184 606</b>	2 604 011 222	<b>153.00</b>	1 604 220 254	<b>89.00</b>	1 607 031 222	<b>19.00</b>	2 607 200 209	<b>108.00</b>
<b>GSB 20-2 RE</b>	<b>0 601 194 706</b>	2 604 010 739	<b>157.00</b>	1 604 220 254	<b>89.00</b>	1 607 031 222	<b>19.00</b>	2 607 200 188	<b>102.00</b>
<b>GSB 20-2 RE</b>	<b>3 601 AA2 1K1</b>	2 609 199 451	<b>127.00</b>	2 609 120 463	<b>52.00</b>	1 617 000 525	<b>13.00</b>	1 607 200 270	<b>42.00</b>
<b>1.0 - 10 mm Drill Chuck with Key 1 608 571 079 37.00</b>									
<b>1.5 - 13mm Drill Chuck with Key 2 609 000 990 52.00</b>									

## Li-Ion Battery Screwdriver/Drill

Model	Part Number	Armature	List Price (RM)	Charger	List Price (RM)	Battery Pack	List Price (RM)	Switch	List Price (RM)
<b>10.8 V</b>									
GDR 1080-LI	3 601 JB3 9L0	2 609 199 418	104.00	1 600 A00 HR3	64.00	1 617 S00 T4M	195.00	2 609 199 478	135.00
GDR 10.8 V-LI	3 601 J09 000	2 609 199 140	95.00	1 600 A00 HR3	64.00	1 617 S00 T4M	195.00	2 609 120 416	143.00
GDR 10.8-LI	3 601 JA6 9B0	2 609 199 281	64.00	1 600 A00 HR3	64.00	1 617 S00 T4M	195.00	1 607 233 5DD	91.00
GDR 10.8 V-EC	3 601 JE0 0B0	2 609 199 661	164.00	1 600 A00 HR3	64.00	2 607 336 879	221.50	1 607 233 581	212.00
GOP 10.8 V-LI	3 601 H58 040	2 609 199 180	110.00	1 600 A00 HR3	64.00	1 617 S00 T4M	195.00	1 607 233 423	222.00
GSA 10.8 V-LI	3 601 F4L 9L0	1 619 P08 652	104.00	1 600 A00 HR3	64.00	1 617 S00 T4M	195.00	1 619 P08 618	188.00
GSC 10.8 V-LI	3 601 J26 100	1 607 000 751	104.00	1 600 A00 HR3	64.00	1 617 S00 T4M	195.00	1 607 233 528	195.00
GSR 1080-2-LI	3 601 JF3 0K0	2 609 199 428	69.00	1 600 A00 HR3	64.00	1 617 S00 T4M	195.00	2 609 125 169	64.00
GSR 1080-LI	3 601 JA8 940	2 609 199 366	77.00	1 600 A00 HR3	64.00	2 607 336 795	221.60	2 609 199 475	100.00
GSR 10.8 V-LI	3 601 J92 U00	2 607 022 840	99.00	1 600 A00 HR3	64.00	1 617 S00 T4M	195.00	2 609 233 073	155.00
GSR 10.8 V-LIQ	3 601 J92 200	2 607 022 838	109.00	1 600 A00 HR3	64.00	1 617 S00 T4M	195.00	1 607 233 352	162.00
GSR 10.8 V-LI-2	3 601 H68 000	2 609 199 177	109.00	1 600 A00 HR3	64.00	1 617 S00 T4M	195.00	1 607 233 508	151.00
GSR 10.8-2-LI	3 601 H68 1B0	2 609 199 258	64.00	1 600 A00 HR3	64.00	1 617 S00 T4M	195.00	1 607 233 485	95.00
GSR 1080-2-LI	3 601 JE2 0K0	2 609 199 724	58.00	1 600 A00 HR3	64.00	1 617 S00 T4M	195.00	2 609 125 169	64.00
GSR 10.8 V-EC	3 601 JD4 0B0	2 609 199 654	156.00	1 600 A00 HR3	64.00	2 607 336 879	131.00	1 607 233 568	222.00
GUS 10.8 V-LI	3 601 JB2 900	1 607 000 751	104.00	1 600 A00 HR3	64.00	1 617 S00 T4M	195.00	1 607 233 528	195.00
GWB 10.8 V-LI	3 601 C90 900	2 610 018 891	52.00	1 600 A00 HR3	64.00	2 607 336 879	131.00	1 607 233 446	195.00
GWJ 10.8 V-LI	3 601 C60 U80	2 609 199 131	63.00	1 600 A00 HR3	64.00	2 607 336 879	131.00	2 609 120 228	204.00
GST 10.8 V-LI	3 601 EA1 040	1 619 P10 586	85.00	1 600 A00 HR3	64.00	2 607 336 879	131.00	1 619 P10 565	188.00
GKS 10.8 V-LI	3 601 FA1 040	1 607 022 64L	106.00	1 600 A00 HR3	64.00	2 607 336 879	131.00	1 619 P10 653	148.00

## Li-Ion Battery Screwdriver/Drill

Model	Part Number	Armature	List Price (RM)	Charger	List Price (RM)	Battery Pack	List Price (RM)	Switch	List Price (RM)
<b>12V</b>									
GSR 12V-30	3 601 JG9 000	1 600 A01 C9M	46.00	1 600 A01 B8Z	135.00	1 600 A00 F6X	145.00	2 607 202 377	29.00
GSB 12V-30	3 601 JG9 100	1 600 A01 C9M	46.00	1 600 A01 B8Z	135.00	1 600 A00 F6X	145.00	2 607 202 377	29.00
GKF 12V-8	3 601 FB0 000	1 607 000 CM2	143.00	1 600 A01 B8Z	135.00	1 600 A00 F6X	145.00	1 607 233 5DH	224.00
GAS 12V-25 PL	3 601 J7C 1L0	1 619 PB3 212	210.00	1 600 A01 B8Z	135.00	1 600 A00 F6X	145.00	1 619 PB3 890	42.00
GSR 12 VEC	3 601 JD4 0L1	2 609 199 654	156.00	1 600 A01 B8Z	135.00	1 600 A00 F6X	145.00	1 607 233 568	222.00
GDR 12 VEC	3 601 JE0 0L0	2 609 199 661	164.00	1 600 A01 B8Z	135.00	1 600 A00 F6X	145.00	1 607 233 581	212.00
GRO 12V-35	3 601 JC5 001	1 619 P11 459	93.00	1 600 A01 B8Z	135.00	1 600 A00 F6X	145.00	1 619 P10 421	156.00
GSR 12 V-15 FC	3 601 JF6 0K0	2 609 199 258	64.00	1 600 A01 B8Z	135.00	1 600 A00 F6X	145.00	1 607 233 5DK	81.00
GWS 12-76-EC	3 601 JF2 0C1	1 600 A00 DC1	141.00	1 600 A01 B8Z	135.00	1 600 A00 F6X	145.00	1 607 233 5A2	120.00
GOP 12V-28	3 601 HB5 0L0	1 607 000 CK9	160.00	1 600 A01 B8Z	135.00	1 600 A00 F6X	145.00	1 607 233 5D5	245.91
GAS 12 V-LI	3 601 JE3 081	-----	-----	1 600 A01 B8Z	135.00	1 600 A00 F6X	145.00	-----	-----
GSA 12 V-LI	3 601 F4L 9L1	1 619 P08 652	104.00	1 600 A01 B8Z	135.00	1 600 A00 F6X	145.00	1 619 P08 618	188.00
GST 12 V-LI	3 601 EA1 0L0	1 619 P10 586	85.00	1 600 A01 B8Z	135.00	1 600 A00 F6X	145.00	1 619 P10 565	188.00
GKF 12V-8	3 601 FB0 000	1 607 000 CM2	143.00	1 600 A01 B8Z	135.00	1 600 A00 F6X	145.00	1 607 233 5DH	224.00
GKS 12 V-LI	3 601 FA1 0L1	1 619 P11 483	104.00	1 600 A01 B8Z	135.00	1 600 A00 F6X	145.00	1 619 P10 653	148.00
GHO 12V-20	3 601 EA7 000	-----	-----	1 600 A01 B8Z	135.00	1 600 A00 F6X	145.00	1 607 233 5D3	313.00
GLI 12V-330	3 601 DA0 001	-----	-----	1 600 A01 B8Z	135.00	1 600 A00 F6X	145.00	-----	-----
<b>18 V</b>									
GAS 18 V-LI	3 601 JC6 150	1 619 PA5 183	67.00	2 607 226 283	95.00	1 600 A00 163	358.00	1 619 PA5 195	117.00
GBH 18 V-LI	3 611 J04 300	1 617 000 6BG	430.00	2 607 226 283	95.00	1 600 A00 163	358.00	1 607 233 376	281.00
GBH 18 V-EC	3 601 J04 000	1 617 000 6BG	430.00	2 607 226 283	95.00	1 600 A00 163	358.00	1 607 233 376	281.00
GCB 18 V-LI	3 601 BA0 300	-----	-----	2 607 226 283	95.00	1 600 A00 163	358.00	1 607 233 448	306.00
GGS 18 V-LI	3 601 JB5 300	1 607 000 D8D	283.00	2 607 226 283	95.00	2 600 A00 163	358.00	1 607 233 340	172.00
GDR 18 V-LI	3 601 JA1 3B1	2 609 199 276	233.00	2 607 226 283	95.00	1 600 A00 163	358.00	1 607 233 480	172.00
GDS 18 V-LI	3 601 JA1 SB1	2 609 199 276	233.00	2 607 226 283	95.00	1 600 A00 163	358.00	1 607 233 480	172.00
GDS 18 V-LI HT	3 601 JB1 3B3	2 610 943 875	424.00	2 607 226 283	95.00	2 607 336 235	774.00	2 610 011 263	433.00
GDX 18 V-LI	3 601 JB8 1B0	2 609 199 508	159.00	2 607 226 283	95.00	2 607 336 235	774.00	1 607 233 480	172.00
GDX 18 V-EC	3 601 JB9 1B0	2 609 199 548	318.00	2 607 226 283	95.00	2 607 336 235	774.00	1 607 233 470	286.00
GHO 18 V-LI	3 601 EA0 300	2 606 625 910	536.00	2 607 226 283	95.00	2 607 336 235	774.00	1 607 233 414	376.00
GKM 18 V-LI	3 601 FA4 000	2 610 034 087	424.00	2 607 226 283	95.00	2 607 336 815	605.00	2 610 029 995	376.00

# Li-Ion Battery Screwdriver/Drill

Model	Part Number	Armature	List Price (RM)	Charger	List Price (RM)	Battery Pack	List Price (RM)	Switch	List Price (RM)
<b>18 V</b>									
GSR 18 V-EC	3 601 JD6 1B0	2 609 199 671	116.00	2 607 226 283	95.00	1 600 A00 163	385.00	1 600 A00 1BG	253.00
GST 18 V-LI	3 601 E8J 300	2 607 022 831	195.00	2 607 226 283	95.00	2 607 336 235	774.00	1 607 233 518	253.00
GWS 18 V-LI	3 601 J3A 300	1 617 000 6B0	253.00	2 607 226 283	95.00	2 607 336 235	774.00	2 607 202 071	35.00
GSR 18V-60 FC	3 601 JG7 1L0	2 609 199 894	77.00	1 600 A00 B8H	235.00	1 600 A01 6GB	270.00	1 607 233 5FR	212.00
GDS 18 VEC 300 ABR	3 601 JD8 2L0	2 609 199 757	116.00	1 600 A01 B92	155.00	1 600 A00 163	385.00	1 600 A00 F9U	376.00
GSA 18 V-32	3 601 FA8 180	1 607 000 CFO	492.00	1 600 A00 B8H	235.00	1 600 A01 6GB	270.00	1 607 233 5A5	430.00
GKS 18 V-57	3 601 FA2 2L0	1 619 P11 898	74.00	1 600 A00 B8H	235.00	1 600 A01 6GK	400.00	1 619 P11 912	119.00
GAS 18 V-1	3 601 JC6 2L0	1 619 PB2 077	93.00	1 600 A00 B8H	235.00	1 600 A01 6GB	270.00	1 619 PB0 706	116.00
GBL 18 V-120	3 601 JF5 1L0	1 619 PA9 071	104.00	1 600 A01 B92	155.00	1 600 A00 163	385.00	1 619 PA9 085	104.00
GOP 18 V-28	3 601 HB6 0L0	1 600 A00 P1T	119.00	1 600 A00 B8H	235.00	1 600 A01 6GB	270.00	1 600 A01 EC4	222.00
GBH 18 V-26	3 611 J09 000	1 600 A00 AR1	81.00	1 600 A00 B8H	235.00	1 600 A01 6GK	400.00	1 607 233 59J	324.00
GSR 18 V-50	3 601 JH5 808	1 607 000 DM8	52.00	1 600 A01 B92	155.00	1 600 A00 1CG	260.00	1 607 000 E1T	41.00
GSR 18 V-50	3 601 JH5 100	1 607 000 DM8	52.00	1 600 A01 B92	155.00	1 600 A00 1CG	260.00	1 607 000 E1T	41.00
GSR 18V 90C solo	3 601 JK6 100	1 600 A02 9PG (rotor)	95.00	1 600 A00 B8H	235.00	1 600 A01 93L	385.00	1 600 A01 6CZ	18.00
GSR 18V 90C solo	3 601 JK6 000	1 600 A02 9PG (rotor)	95.00	1 600 A00 B8H	235.00	1 600 A01 93L	385.00	2 607 202 904	44.00
GDS 18 V-1000	3 601 JJ8 3L0	1 607 022 67X	336.00	1 600 A01 9S7	555.00	1 600 A01 93N	545.00	2 607 202 501	32.00
GDS 18 V-1050H	3 601 JJ8 5L0	1 607 022 67X	336.00	1 600 A01 B92	155.00	1 600 A00 1CG	260.00	2 607 202 501	32.00
GSR 18 V-150C	3 601 JJ5 000	1 600 A02 4CL	307.00	1 600 A01 B92	155.00	1 600 A00 1CG	260.00	2 607 202 501	32.00
GSB 18 V-150C	3 601 JJ5 100	1 600 A02 4CL	307.00	1 600 A01 B92	155.00	1 600 A00 1CG	260.00	2 607 202 501	32.00
GBH 18 V-34CF	3 611 J14 080	1 607 000 DL7	417.77	1 600 A01 B92	155.00	1 600 A00 1CG	260.00	2 607 202 360	68.00
GBH 18 V-36C	3 611 J15 080	1 607 000 DL7	417.77	1 600 A01 B92	155.00	1 600 A00 1CG	260.00	2 607 202 360	68.00
GBH 18 V-45C	3 611 J13 080	1 607 000 DN4	483.48	1 600 A01 B92	155.00	1 600 A00 1CG	260.00	2 607 202 360	68.00
GKS 18 V-68 GC	3 601 FB5 101	-----	-----	1 600 A01 B92	155.00	1 600 A00 1CG	260.00	1 600 A01 3WF	123.00
GTS 18 V-216	3 601 M44 0K0	1 607 022 67K	483.48	1 600 A01 B92	155.00	1 600 A00 1CG	260.00	2 607 202 394	44.44
GCM 18 V-216	3 601 M41 0K0	1 607 022 66T	417.77	1 600 A01 B92	155.00	1 600 A00 1CG	260.00	2 607 202 382	34.43
GCM 18 V-305 GDC	3 601 M43 0K0	1 607 022 67D	560.00	1 600 A01 B92	155.00	1 600 A00 1CG	260.00	2 607 202 510	43.00
GWS 18 V-15 SC	3 601 JH6 303	1 607 022 661	393.00	1 600 A01 B92	155.00	1 600 A00 1CG	260.00	1 600 A01 6JC	46.00
GWS 18V-10	3 601 JJ4 0L0	1 607 000 CA4	253.00	1 600 A01 B92	155.00	1 600 A00 1CG	260.00	2 607 202 328	45.00
GWS 18V-10P	3 601 JJ4 1K0	1 607 000 CA4	253.00	1 600 A01 9S7	555.00	1 600 A01 93N	545.00	2 607 202 328	45.00
GWS 18V 15 PSC	3 601 JH6 B02	1 607 022 661	393.00	1 600 A01 9S7	555.00	1 600 A01 93N	545.00	2 600 A01 6JC	46.00
GWS 18V 180 P	3 601 JH6 L04	1 607 022 661	393.00	1 600 A01 9S7	555.00	1 600 A01 93N	545.00	2 600 A01 6JC	46.00
GDX 18V-200 C	3 601 JG4 200	1 619 P14 405	77.00	1 600 A01 B92	155.00	1 600 A00 1CG	260.00	1 607 233 5EV	281.00
GDS 18V-400	3 601 JK0 080	1 600 A01 RX5	87.00	1 600 A01 B92	155.00	1 600 A00 1CG	260.00	2 607 202 509	104.00
GSR 18V-60 FC	3 601 JG7 1L0	2 609 199 894	77.00	1 600 A00 B8H	235.00	1 600 A01 6GB	270.00	1 607 233 5FR	212.00
GLI 18V-LI	3 601 D37 S00	-----	-----	1 600 A01 B92	155.00	1 600 A00 1CG	260.00	-----	-----
GLI 18V-1900	3 601 D46 500	-----	-----	1 600 A01 B92	155.00	1 600 A00 1CG	260.00	-----	-----
GSA 18 V-LI C	3 601 FA5 000	1 619 P12 758	172.00	1 600 A01 B92	155.00	1 600 A00 1CG	260.00	1 619 P11 964	188.00
GSA 18 V-32	3 601 FA8 180	1 607 000 CFO	492.00	1 600 A01 B92	155.00	1 600 A01 6GB	270.00	1 607 233 5A5	430.00
GST 18 V-LI B	3 601 EA6 101	2 607 022 831	195.00	1 600 A01 B92	155.00	1 600 A00 1CG	260.00	1 607 233 518	253.00
GGS 18 V-LI	3 601 JB5 300	1 607 000 D8D	283.00	1 600 A01 B92	155.00	1 600 A00 1CG	260.00	1 607 233 340	172.00
GAS 18 V-10L	3 601 JC6 3K0	1 600 A02 GT4	158.00	1 600 A01 B92	155.00	1 600 A00 1CG	260.00	1 600 A01 1G2	143.00
GCB 18V-63	3 601 BA0 400	2 610 013 561	257.00	1 600 A01 B92	155.00	1 600 A00 1CG	260.00	2 610 021 159	300.00
GBH 18V-26	3 611 J09 000	1 605 108 2B8 (Motor Housing)	6.00	1 600 A01 B92	155.00	1 600 A00 1CG	260.00	1 607 233 59J	324.00
GDE 18V-16	1 600 A00 51N	1 607 000 CA3	86.00	1 600 A01 B92	155.00	1 600 A00 1CG	260.00	1 607 233 5A7	76.00
GRG 18V-16 C SOLO	3 601 JK5 080	1 619 PB8 308	232.00	1 600 A00 B8H	235.00	1 600 A01 93L	385.00	1 619 PB6 096	225.00
GKM 18V-50 solo	3 601 FB8 000	2 610 034 087	424.00	1 600 A01 B92	155.00	1 600 A00 163	385.00	1 619 PB4 911	71.00
GBH 18V 40 C	3 611 J17 100	1 607 000 E8R	587.00	1 600 A01 9S7	555.00	1 600 A01 93N	545.00	2 607 202 360	68.00

### GSR 18V-60 FC Attachments

Chuck Attachment (GFA 18-M)	1 600 A00 ZS9	163.00
Chuck Attachment (GFA 18-B)	2 609 199 634	190.00
Right Angle Attachment (GFA 18-W)	1 600 A00 RR2	156.00
Eccentric Attachment (GFA 18-E)	2 609 199 636	190.00
Right Angle Attachment (GFA 18-WB)	2 609 199 635	190.00
SDS Attachment	1 600 A00 3ND	190.00

### 36 V

GBH 36 V LI	3 611 J00 R00	1 617 000 473	344.00	2 607 226 459	324.00	1 600 A00 1ZJ	545.00	1 607 233 209	441.00
GBH 36 V-LI Compact	3 611 J03 R00	1 617 000 664	510.00	2 607 226 459	324.00	1 600 A00 L1M	900.00	1 607 233 316	441.00
GAL 3680 CV ( for 36V)				2 607 226 459	324.00				
GBH 36V-LI Plus	3 611 J06 001	1 607 022 672	324.00	2 607 226 459	324.00	1 600 A00 L1M	900.00	1 600 A00 A4B	178.00

## Rotary Hammer / Demolition Hammer

Model	Part Number	Armature	List Price (RM)	Stator	List Price (RM)	Carbon	List Price (RM)	Switch	List Price (RM)
GBH 220	3 611 BA6 0L0	1 619 P16 276	76.00	1 616 B10 269	32.00	1 617 000 525	13.00	1 607 200 372	40.00
GBH 2-20 RE	3 611 B5A 3L0	1 619 P09 818	143.00	1 619 P08 313	45.00	1 617 014 146	24.00	1 617 200 542	70.00
GBH 2-20 DRE	3 611 B5A 4L0	1 619 P09 818	143.00	1 619 P08 313	45.00	1 617 014 146	24.00	1 617 200 542	70.00
GBH 2-23 REA	3 611 B50 570	1 619 P06 110	249.00	1 619 P02 042	74.00	1 617 000 525	13.00	1 617 200 532	40.00
GBH 2-23 RE	3 611 B50 4L0	1 617 000 561	232.00	2 604 220 693	73.00	1 617 000 525	13.00	1 617 200 532	40.00
GBH 2-24 DFR	0 611 228 742	1 614 010 230	210.00	1 614 220 171	65.00	1 617 014 134	18.00	1 617 200 077	117.00
GBH 2-26 RE	0 611 251 706	1 614 010 235	90.00	1 614 220 127	53.00	1 617 000 525	13.00	1 617 200 532	40.00
GBH 2-24 DRE	3 611 B72 1L0	1 619 P13 626	80.00	1 619 P12 748	40.00	1 617 000 525	13.00	1 607 200 32D	29.00
GBH 2-26 DRE	0 611 253 76C	1 614 010 235	90.00	1 614 220 127	53.00	1 617 000 525	13.00	1 617 200 532	40.00
GBH 2-26 DFR	0 611 254 706	1 614 010 235	90.00	1 614 220 127	53.00	1 617 000 525	13.00	1 617 200 532	40.00
GBH 2-28 D	3 611 B67 0L0	1 614 010 281	172.00	1 614 220 222	53.00	1 617 000 525	13.00	1 617 200 532	40.00
GBH 2-28 DFV	3 611 B67 2L0	1 614 010 281	172.00	1 614 220 222	53.00	1 617 000 525	13.00	1 617 200 532	40.00
GBH 3-28 E	0 611 239 706	1 614 010 708	254.00	1 614 220 155	67.00	1 617 014 137	21.00	2 607 200 576	65.00
GBH 3-28 DFR	3 611 B4A 0L0	1 617 000 690	292.00	1 614 220 117	88.00	1 617 000 525	13.00	1 617 200 127	66.00
GBH 4-32 DFR	3 611 C32 1L5	1 614 010 252	294.00	1 614 220 190	85.00	1 614 321 079	39.00	1 617 200 127	66.00
GBH 5/40 DCE	0 611 216 742	1 614 010 180	404.00	1 604 220 343	104.00	1 617 014 122	40.00	1 617 200 048	92.00
GBH 5/40 DCE	3 611 B64 000	1 614 011 098	468.00	1 614 220 123	102.00	1 617 014 144	42.00	1 617 200 120	77.00
GBH 5-40 D	3 611 B69 0L0	1 619 P10 769	222.00	1 619 P08 323	85.00	1 607 031 245	17.00	1 619 P10 396	58.00
GBH 5 DCE	0 611 230 706	1 614 010 186	387.00	1 604 220 343	104.00	1 607 031 225	33.00	1 617 200 048	92.00
GBH 7 DE	0 611 235 706	1 614 010 213	589.00	1 614 220 124	85.00	1 617 014 135	42.00	1 617 200 048	92.00
GBH 7/45 DE	0 611 214 742	1 614 011 038	760.00	1 614 220 090	714.00	1 617 014 110	42.00	1 617 200 040	92.00
GBH 7/46 DE	0 611 263 706	1 614 010 213	589.00	1 614 220 124	85.00	1 617 014 135	42.00	1 617 200 048	92.00
GBH 8-45 D	3 611 B65 1L0	1 614 010 267	492.00	1 614 220 124	85.00	1 617 000 A50	58.00	1 617 200 130	77.00
GBH 8-45 DV	3 611 B65 0L0	1 614 010 267	492.00	1 614 220 124	85.00	1 617 014 145	40.00	1 617 200 130	77.00
GSH 3 E	0 611 320 737	1 614 010 238	398.00	1 614 220 179	83.00	1 614 014 137	21.00	1 607 200 524	53.00
GSH 388	0 611 388 006	1 619 P04 545	244.00	1 619 P01 908	86.00	1 607 031 245	17.00	1 617 200 110	55.00
GSH 5	3 611 C37 0L0	1 619 P10 090	212.00	1 619 P05 386	83.00	1 607 031 245	17.00	1 619 P07 720	32.00
GSH 5 X	3 611 C38 2L0	1 619 P09 697	106.00	1 619 P08 302	64.00	1 607 031 245	17.00	1 619 P09 019	27.00
GSH 5 E	0 611 318 703	1 614 011 098	468.00	1 614 220 123	102.00	1 617 014 144	42.00	1 617 200 095	50.00
GSH 5 CE	3 611 C21 0L0	1 614 011 098	468.00	1 614 220 123	102.00	1 617 014 144	42.00	1 617 200 102	91.00
GSH 500 GEN II	3 611 C38 6L0	1 619 P10 301 (Motor Housing )	40.00	1 619 P14 780	94.00	1 617 014 138	17.00	1 619 P09 019	27.00
GSH 9 VC	3 611 C22 0L0	1 614 010 267	492.00	1 614 220 124	85.00	1 617 000 A50	58.00	1 617 200 130	77.00
GSH 11 E	0 611 316 706	1 614 011 072	522.00	1 604 220 52J	188.00	1 607 031 227	35.00	1 617 200 048	92.00
GSH 11 VC	3 611 C36 070	1 614 011 120	536.00	1 604 220 52F	195.00	1 617 000 750	40.00	1 607 200 244	77.00
GSH 14 C	3 611 C44 0L0	1 619 P17 697	527.00	1 600 A02 1VS	207.00	-----	-----	1 619 P16 790	14.00
GSH 16-30	3 611 C35 1L0	1 614 011 117	657.00	1 604 220 52M	398.00	1 617 014 143	56.00	1 607 200 244	77.00
GSH 27	0 611 304 142	1 617 000 849	1434.00	1 614 220 156	459.00	1 617 000 425	74.00	1 617 200 108	191.00
GSH 27 VC	3 611 C0A 070	1 614 011 139	983.00	1 614 220 207	406.00	1 617 000 425	74.00	1 617 200 124	104.00
GBH 5-40 DCE	3 611 B64 003	1 614 011 098	468.00	1 614 220 123	102.00	1 617 014 144	42.00	1 617 200 120	77.00



## Straight Grinder

Model	Part Number	Armature	List Price (RM)	Stator	List Price (RM)	Carbon	List Price (RM)	Switch	List Price (RM)
GGG 6	0 601 214 042	1 604 010 474	462.00	3 604 220 110	128.00	3 607 014 012	46.00	1 607 200 064	107.00
GGG 6 S	0 601 214 103	1 604 010 474	462.00	3 604 220 134	518.00	3 607 014 012	46.00	1 607 200 064	107.00
GGG 27	0 601 210 006	2 604 010 918	199.00	2 604 220 462	94.00	1 607 031 228	19.00	2 607 200 093	48.00
GGG 27 L	0 601 215 006	2 604 010 659	229.00	2 604 220 441	101.00	3 607 031 630	29.00	2 607 200 674	38.00
GGG 3000 L	3 601 B24 010	1 619 P08 207	82.00	1 619 P09 835	57.00	1 607 031 223	10.00	1 607 200 146	16.00
GGG 5000	3 601 B24 110	1 619 P08 212	82.00	1 619 P09 888	61.00	1 607 014 145	10.00	1 607 200 146	16.00
GGG 5000 L	3 601 B24 110	1 619 P08 212	82.00	1 619 P09 888	61.00	1 607 031 223	10.00	1 607 200 146	16.00
GGG 28 C	3 601 B20 070	3 607 030 476	195.00	3 607 030 475	143.00	1 607 014 176	27.00	1 607 200 199	34.00
GGG 28 LC	3 601 B21 000	3 607 030 476	195.00	3 607 030 475	143.00	1 607 014 176	27.00	1 607 200 199	34.00
	6 mm Collet for GGS 27 L	2 608 570 129	48.00	6mm Collet for GGS 5000 L		1 619 P10 661	11.00		
	Nut for GGS 27 L	3 603 342 009	12.00	6mm Collet for GGS 5000 L		1 619 P09 252	20.00		
				6mm collet & nut GGS 28 LC		3 607 030 474	52.00		

## Angle Grinder

GWS 580	0 601 376 1X0	2 609 120 101	31.00	2 609 120 100	27.00	1 607 014 145	10.00	1 607 200 179	16.00
GWS 6-100 E	0 601 375 0A6	1 604 010 626	117.00	2 609 160 011	70.00	1 607 031 223	10.00	1 607 200 179	16.00
GWS 7-100 T	3 601 C88 040	1 619 P05 274	42.00	1 619 P07 367	30.00	1 619 P02 870	10.00	1 607 200 179	16.00
GWS 7-100 ET	3 601 C88 510	1 619 P05 274	42.00	1 619 P07 367	30.00	1 619 P02 870	10.00	1 607 200 146	16.00
GWS 750-100	3 601 C94 010	1 604 010 667	55.00	1 619 P08 334	39.00	1 607 031 223	10.00	1 607 200 238	20.00
GWS 8-100 CE	0 601 377 6A6	1 604 010 667	105.00	1 604 220 340	49.00	1 607 031 223	10.00	1 607 200 146	16.00
GWS 8-100 Z	3 601 H31 510	1 604 010 633	172.00	1 604 220 340	49.00	1 607 031 223	10.00	1 607 200 146	16.00
GWS 13-125 CI	3 601 G9E 000	1 607 000 V33	188.00	1 604 220 527	77.00	1 607 000 V37	31.00	1 607 200 256	26.00
GWS 17-125 CI	3 601 G9G 000	1 607 000 V35	222.00	1 604 220 532	85.00	1 607 000 V37	31.00	1 607 200 256	26.00
GWS 17-150 CI	3 601 G9K 000	1 607 000 V36	222.00	1 604 220 532	85.00	1 607 000 V37	31.00	1 607 200 256	26.00
GWS 060	3 601 C75 610	1 619 P01 844	28.00	1 619 P12 316	22.00	1 619 P07 571	8.00	1 607 200 32E	15.00
GWS 14-125 C	0 601 704 703	1 604 010 650	210.00	1 604 220 284	110.00	1 607 014 176	27.00	1 607 200 137	32.00
GWS 14-125 CI	3 601 H24 000	1 604 010 A22	232.00	1 607 000 397	110.00	1 607 014 176	27.00	1 607 200 200	34.00
GWS 14-125 Inox	3 601 H29 J00	1 604 010 A23	262.00	1 607 000 397	110.00	1 607 014 176	27.00	1 607 200 200	34.00
GWS 12-125	3 601 G93 070	1 607 000 V33	188.00	1 604 220 475	77.00	1 607 000 V37	31.00	1 607 200 256	26.00
GWS 12-125 s	3 601 CA6 0K2	1 619 P20 936 <sup>(motor housing)</sup>	14.00	1 619 P21 170	61.00	1 619 P21 172	15.00	1 607 200 31S	4.00
GWS 13-125 CI	3 601 G9E 070	1 607 000 V33	188.00	1 604 220 527	77.00	1 607 000 V37	31.00	1 607 200 256	26.00
GWS 15-125 CI	3 601 G95 000	1 607 000 V35	222.00	1 604 220 532	85.00	1 607 000 V37	31.00	1 607 200 256	26.00
GWS 15-150 CI	3 601 G98 000	1 607 000 V36	222.00	1 604 220 532	85.00	1 607 000 V37	31.00	1 607 200 256	26.00
GWS 20-180	0 601 849 1B6	1 604 011 252	117.00	1 604 220 380	74.00	1 607 014 171	16.00	1 607 000 967	51.00
GWS 22-180	3 601 H81 AL0	1 604 011 296	262.00	1 619 220 435	74.00	1 607 014 171	16.00	1 607 000 967	51.00
GWS 20-180	0 601 356 006	1 604 011 148	346.00	1 604 220 386	199.00	1 607 014 171	16.00	1 607 200 103	101.00
GWS 23-180	0 601 850 1B6	1 604 011 252	117.00	1 604 220 380	74.00	1 607 014 171	16.00	1 607 000 967	51.00
GWS 20-230 H	0 601 850 006	1 604 011 252	117.00	1 604 220 380	74.00	1 607 014 171	16.00	1 607 000 967	51.00
GWS 22-180 LV	3 601 H90 E80	1 604 011 297	259.00	1 604 220 53X	195.00	1 607 014 171	16.00	1 607 000 973	182.00
GWS 26-230 B	0 601 856 003	1 604 011 932	374.00	1 604 220 382	157.00	1 607 014 171	16.00	1 607 000 967	51.00
GWS 900-100	3 601 C96 0L3	1 619 P10 952	52.00	1 619 P10 953	46.00	1 619 P11 715	12.00	1 607 200 31Y	20.00
GWS 900-100 S	3 601 C96 1L3	1 619 P10 952	52.00	1 619 P10 953	46.00	1 619 P11 715	12.00	1 607 200 31S	4.00
GWS 9-100 P	3 601 C96 510	1 619 P10 952	52.00	1 619 P10 953	46.00	1 619 P11 715	12.00	1 607 200 31X	17.00
GWS 18-125 L	3 601 GA3 0L0	1 604 010 B98	255.00	1 604 220 56P	103.00	1 604 321 186	29.00	1 607 000 D16	29.00
GWS 24-180 JZ	3 601 HC2 3L0	1 619 P16 541	207.00	1 619 P14 999	174.00	1 607 014 171 <sup>(Carbon brush set)</sup>	16.00	1 619 P16 542	127.00
GWS 24-230 JZ	3 601 HC3 3L0	1 619 P16 541	207.00	1 619 P14 999	174.00	1 607 014 171 <sup>(Carbon brush set)</sup>	16.00	1 619 P16 542	127.00
GWS 2200-180	3 601 HF1 0E0	1 619 P15 748	146.00	1 619 P15 000	99.00	1 607 014 171 <sup>(Carbon brush set)</sup>	16.00	1 619 P14 968	36.00
GWS 30-180 B	3 601 HF0 0L0	1 619 P17 480 <sup>(rotor)</sup>	307.00	1 619 P17 476	259.00			1 619 P14 968	400.00
GWS 2200-230	3 601 HF2 0E0	1 619 P15 748	146.00	1 604 220 58H	159.87	1 607 014 171	16.00	1 619 P14 968	36.00
GWS 30-230 B	3 601 HG1 0L0	1 619 P17 480 <sup>(rotor)</sup>	307.00	1 619 P17 476	229.00			1 619 P17 478	36.00
GWX 14-125	3 601 GB7 000	1 604 010 A90	195.00	1 607 000 397	110.00	1 607 014 176 <sup>(Carbon brush set)</sup>	27.00	1 607 200 200	34.00
GWX 18V-10 PC Solo	3 601 GB0 700	1 607 000 CA4	253.00	-----	-----	-----	-----	1 607 503 438	44.00
GWX 18V-10 C Solo	3 601 GB0 200	1 607 000 CA4	253.00	-----	-----	-----	-----	1 607 503 438	44.00
GWX 18V-15 SC Solo	3 601 JH6 502	1 607 022 661	393.00	-----	-----	-----	-----	1 607 000 DK3	360.12
M10 Round Nut (4" grinder)		1 619 P09 976	5.00	Pin Spanner (4" grinder)		2 609 110 015	4.00		
M10 Flange (4" grinder)		1 605 703 113	4.00	Protection Guard (4" grinder)		1 619 P02 838	27.00		

## Bench Grinder / Wet Grinder / Polisher / Compound Miter Saw / Cut Off Machine

Model	Part Number	Armature	Stator	List Price (RM)	Carbon	Switch	List Price (RM)
GBG 6	3 601 B7A 0L0	1 619 PA2 264	1 609 B00 115	80.00	1 607 014 171	1 619 PA1 962	77.00
GBG 8	3 601 B7A 1L0	1 619 PA2 265	1 609 B00 115	93.00	1 607 014 171	1 619 PA1 962	77.00
GCD 12 JL	3 601 M28 0L0	1 609 B04 679	1 609 B00 115	413.00	1 607 014 171	1 609 B05 400	46.00
GCM 10	0 601 B20 006	1 609 P03 J08	1 609 B00 115	455.00	1 619 P04 451	1 609 203 H99	34.00
GCM 10 S	0 601 B20 542	1 619 P03 776	1 609 203 J56	397.00	1 609 203 L02	2 601 011 717	117.00
GCM 10 M	3 601 M20 1L0	1 609 B00 879	1 609 B00 119	303.00	1 607 014 171	1 609 B00 882	31.00
GCM 10 MX	3 601 M29 0L0	1 619 PA7 056	1 619 PA6 835	254.00	1 619 PA7 057	1 619 PA6 703	24.00
GCM 10 GDJ	3 601 M27 0L0	1 609 B02 590	1 609 B02 484	376.00	2 610 021 311	2 610 950 336	40.00
GCM 800 S	3 601 L16 1L0	1 619 P03 495	1 619 P03 494	358.00	1 619 P04 451	1 619 P03 496	30.00
GCM 8 SJL	3 601 M19 1L0	1 609 B03 793	1 619 P04 474	324.00	1 609 B03 790	1 609 B04 211	26.00
GCM 12 GDL	3 601 M23 670	1 609 B02 590	1 609 B02 484	376.00	2 610 021 311	2 610 950 336	40.00
GTM 12	3 601 M15 070	1 619 P04 101	1 619 P04 105	306.00	1 619 P04 451	1 619 P04 138	128.00
GTS 10 J	3 601 M30 5L0	1 619 P03 278	1 609 203 K86	324.00	2 610 018 332	2 610 016 997	134.00
GCO 14-2	0 601 B11 006	1 609 902 411	1 609 902 404	249.00	1 609 902 320	1 609 203 F31	49.00
GCO 2000	3 601 L17 0L0/1	1 609 B00 046	1 619 P03 860	106.00	1 607 014 171	1 619 P03 844	19.00
GCO 200	3 601 M37 0L0	1 609 B03 639	1 609 B00 135	106.00	1 607 014 171	1 609 B03 606	19.00
GCO 2000	3 601 L17 0L2	1 609 B03 566	1 609 B00 129	106.00	1 607 014 171	1 619 P03 844	19.00
GSM 200	0 601 277 103	1 609 203 620	1 609 203 305	150.00	-----	1 609 203 241	28.00
GPO 12 CE	3 601 C89 0L0	1 619 P09 115	1 604 220 417	159.00	1 607 014 176	1 607 200 257	67.00
GPO 14 E	0 601 366 678	F 000 605 024	F 000 607 063	276.00	9 618 086 921	9 618 086 632	99.00
GBG 35-15	3 601 B7A 3L0	1 619 PB1 470	1 619 PB1 468	37.00	-----	1 619 PB1 472	10.00
GBG 60-20	3 601 B7A 4L0	1 619 PB1 471	1 619 PB1 469	70.00	-----	1 619 PB1 472	10.00
GTS 254	3 601 M45 0L0	1 619 PB7 256	1 604 220 58V	220.00	1 619 PB6 280	1 607 200 37L	43.00
GPO 950	3 601 CA2 0L0	1 619 PB1 970	1 619 PB1 969	93.00	1 619 PB1 971	1 619 PB1 744	20.00
GCO 14-24 J	3 601 M37 2L0	1 609 B03 591	1 609 B00 149	128.00	1 607 014 171	1 609 B02 146	31.28
GCM 216	3 601 M33 000	1 619 PB6 251 (Motor Housing)	1 619 PB6 108	33.00	1 619 PB6 115	1 619 PB6 110	8.00
GCO 220	3 601 M37 3L0	1 609 B03 639	1 609 B00 135	106.00	1 607 014 171	1 609 B03 606	19.00

## Screwdriver / Impact Wrench

GSR 6-25 TE	3 601 D41 300	2 604 011 928	2 604 220 456	197.00	2 604 321 943	2 607 200 638	133.00
GSR 6-40 TE	3 601 D40 300	2 604 011 908	2 604 220 456	186.00	2 604 321 943	2 607 200 638	133.00
GSR 6-25 TE	3 601 D45 0P0	2 604 011 941	2 604 220 456	188.00	2 604 321 943	2 607 200 638	133.00
GSR 6-45 TE	3 601 D45 1P0	2 604 011 943	2 604 220 456	188.00	2 604 321 943	2 607 200 638	133.00

## Shear / Nibbler / Foam Rubber Cutter / Blower

GSC 2.8	0 601 506 142	2 604 010 609	2 604 220 462	240.00	1 607 031 228	2 607 200 674	40.00
GNA 2.0	0 601 530 142	2 604 010 609	2 604 220 462	240.00	1 607 031 228	2 607 200 674	40.00
GSG 300	0 601 575 103	2 604 010 826	2 604 220 503	190.00	1 607 014 17J	2 607 200 286	38.00
GBL 800E	3 601 J80 4L0	1 604 010 A58	1 604 220 439	104.00	1 604 321 129	2 607 200 637	22.00
GRW 12 E	3 601 AA7 070	1 604 010 B1U	1 604 220 23S	430.00	1 607 014 17A	1 607 200 313	77.00
GBL 620	3 601 J80 5K0	1 604 010 BA6	1 604 220 56J	78.00	1 604 321 129	2 607 200 637	22.00
GBL 82-270	3 601 J80 4L5	1 604 010 B1E	1 604 220 439	104.00	1 604 321 129	2 607 200 637	22.00
GOP 30-28	3 601 B37 0K1	2 609 199 961	-----	188.00	1 619 P02 870	1 607 233 437	128.00

Valid in West Malaysia and while stocks last only.

## Jigsaw

Model	Part Number	Armature	List Price (RM)	Stator	List Price (RM)	Carbon	List Price (RM)	Switch	List Price (RM)
GST 54	0 601 58A 006	2 604 010 559	110.00	2 604 220 392	51.00	2 604 321 919	17.00	2 607 200 260	28.00
GST 65	3 601 E09 1L0	1 619 P01 958	133.00	1 619 P01 961	60.00	2 604 321 919	17.00	2 607 200 637	22.00
GST 60 PB	0 601 581 206	2 604 010 578	152.00	2 604 220 438	66.00	1 607 031 228	19.00	2 607 200 260	28.00
GST 60 PBE	0 601 581 506	2 604 010 578	152.00	2 604 220 438	66.00	2 604 320 912	19.00	2 607 200 260	28.00
GST 75 BE	0 603 382 706	2 604 011 234	133.00	2 604 220 655	70.00	2 604 321 925	17.00	2 607 200 581	66.00
GST 80 PB	3 601 E81 29F	2 604 010 578	152.00	2 604 220 447	74.00	2 604 320 912	19.00	2 607 200 260	28.00
GST 80 PBE	3 601 E81 59F	2 604 010 578	152.00	2 604 220 477	74.00	1 607 031 228	19.00	2 607 200 190	109.00
GST 25 M	3 601 E16 0L0	1 619 P05 282	92.00	1 619 P05 382	39.00	2 604 320 912	19.00	1 619 P07 689	34.00
GST 700	3 601 BA7 0L0	1 619 P14 567	67.00	1 619 P14 566	23.00	1 619 P13 476 <sup>(Carbon-Brush Set)</sup>	8.00	2 607 200 678	35.00
GST 90 BE	3 601 E8F 0L0	1 619 P08 887	74.00	1 619 P09 154	127.00	2 604 321 925 <sup>(Carbon-Brush Set)</sup>	17.00	2 607 200 669	42.00

## Concrete Cutter

GDM 12-34	3 601 C6A 1L0	1 619 P00 962	90.00	1 619 P01 044	73.00	1 619 P01 033	19.00	1 619 P00 436	21.00
GDM 13-34	3 601 C6A 2L0	1 619 P06 303	93.00	1 619 P08 588	77.00	1 619 P06 304	16.00	1 619 P09 074	17.00
GDM 121	3 601 C95 0L0	1 619 PA9 243	58.00	1 619 PA7 559	37.00	1 619 PA4 025	8.00	1 619 PA7 561	5.00

## Circular Saw

GKS 165	3 601 E22 0K0	1 619 P01 310	143.00	1 619 P01 131	88.00	1 619 P01 317	19.00	1 619 P01 161	77.00
GKS 66 X	3 601 F76 1L0	1 619 P11 497	146.00	1 619 P08 314	98.00	1 619 P10 063	15.00	1 619 P10 149	11.00
GKS 190	3 601 E23 0L0	1 619 P01 310	143.00	1 619 P01 131	88.00	1 619 P01 317	19.00	1 619 P01 161	77.00
GKS 190	3 601 F23 0L0	1 619 P06 345	189.00	1 619 P04 474	85.00	1 619 P06 346	32.00	1 619 P06 206	37.00
GKS 235	3 601 E7A 0L0	1 619 P01 696	220.00	1 619 P08 320	102.00	1 619 P01 685	30.00	1 619 P01 115	82.00
GKS 235 TURBO	3 601 EA2 0L0	1 619 P10 475	223.00	1 619 P08 335	117.00	1 619 P10 476	21.00	1 607 200 286	48.00
GKS 600	3 601 FA9 0L0	1 619 P14 131	66.00	1 619 P08 314	98.00	1 619 P10 063 <sup>(Carbon-Brush Set)</sup>	15.00	1 619 P09 971	20.00
GKS 140	3 601 FB3 0L1	1 604 010 B9J	97.00	1 607 000 D17	52.00	1 619 PB4 042 <sup>(Carbon-Brush Set)</sup>	21.00	1 619 PB3 945	13.00

## All Purpose Saw / Multi Saw / Sabre Saw

GOP 250 CE	3 601 B30 070	2 609 199 334	156.00	2 609 199 344	116.00	1 619 P02 870	10.00	2 609 125 028	40.00
GSA 1100 PE	0 601 634 703	2 610 908 849	436.00	2 610 908 848	119.00	2 601 007 957	23.00	2 607 200 209	108.00
GSA 1100 E	3 601 F4C 8L0	2 610 956 920	138.00	2 610 956 919	81.00	2 610 956 917	13.00	1 619 PA1 684	73.00
GSA 1300 PCE	3 601 F4E 2L0	2 610 015 637	276.00	2 610 015 551	114.00	2 610 013 260	28.00	2 610 013 496	77.00
GSA 120	3 601 FB1 0L0	1 604 010 BB9	115.00	1 604 220 57W	81.00	1 619 P10 063	15.00	1 607 200 358	46.00

## Planer / Orbital Sander

Model	Part Number	Motor	Stator	List Price (RM)	Carbon	List Price (RM)	Switch	List Price (RM)
GHO 10-82	0 601 594 006	2 609 199 269	2 604 220 480	94.00	2 609 120 064	66.00	1 607 200 157	28.00
GSS 1400	3 601 BA2 0L0	2 609 199 883	1 604 220 408	58.00	2 609 120 199	51.00	1 607 200 190	28.00
GSS 230 A	0 601 292 003	2 604 011 110	2 604 220 529	114.00	1 607 031 234	97.00	2 607 200 260	28.00
GSS 230 AE	0 601 292 703	2 604 011 110	2 604 220 529	114.00	1 607 031 234	97.00	2 607 200 260	28.00
GSS 230	3 601 K70 0L0	2 609 199 085	1 604 220 408	105.00	2 609 120 199	51.00	2 607 200 632	29.00
GSS 280 A	0 601 293 006	2 604 011 110	2 604 220 529	114.00	1 607 031 234	97.00	2 607 200 260	28.00
GSS 280 AVE	3 601 B92 900	2 604 011 952	2 604 220 750	212.00	1 607 031 234	75.00	2 607 200 688	22.00
GBS 75 A	0 601 274 004	2 604 010 935	2 604 220 480	286.00	1 607 031 222	66.00	2 607 200 084	28.00
GHO 6500	3 601 E96 0L0	1 619 PA7 993	1 619 PA7 991	58.00	2 609 120 398	46.00	1 619 PA7 983	20.00
GSS 140	3 601 BA8 0L0	1 604 010 B9N	1 604 220 577	40.00	1 619 PB3 111 <sup>(Carbon-Brush Set)</sup>	26.00	1 607 200 35P	12.00
GSS 2300	3 601 B98 0L0	1 619 PA7 629	1 619 PA7 627 <sup>(Field assembly 220-240V)</sup>	52.00	1 619 PA7 635 <sup>(Carbon-Brush Set)</sup>	46.00	1 619 PA7 631	15.00

## Multi Sander / Router / Mini Router

PEX 11 A / PEX 11 AE	0 603 309 006	2 604 011 019	2 604 220 539	117.00	1 607 031 222	74.00	2 607 200 260	28.00
PEX 12 A / PEX 12 AE	0 603 310 706	2 604 011 266	2 605 104 801	162.00	2 604 321 917	60.00	2 607 200 260	28.00
GEX 125-1 A	3 601 C87 0L0	2 609 199 164	2 609 120 299	218.00	2 609 120 199	66.00	1 607 200 190	28.00
GEX 125-1 AE	3 601 C87 5L0	2 609 199 164	2 609 120 299	218.00	2 609 120 199	66.00	1 607 200 190	28.00
GEX 270 A	0 601 37A 006	2 604 010 985	2 604 220 681	122.00	2 604 321 925	67.00	2 607 200 526	26.00
GEX 270 AE	0 601 37A 706	2 604 010 985	2 604 220 681	122.00	2 604 321 925	67.00	2 607 200 526	26.00
GMR 1	3 601 FOA 0L0	2 609 120 168	2 609 120 169	130.00	2 609 120 149	104.00	2 609 120 274	27.00
GOF 1600 CE	3 601 F24 0L0	2 610 025 596	1 619 P05 305	281.00	2 610 007 957	128.00	2 610 001 608	13.00
GKF 550	3 601 FA0 0L1	1 619 PB3 148	1 619 PB3 028 <sup>(Field assembly 220-240V)</sup>	91.00	1 619 PB3 047	61.00	1 619 PB3 034	13.00
GOF 130	3 601 FB7 0L0	1 619 PB5 443	1 619 PB5 441 <sup>(Field assembly 220-240V, 50-60Hz)</sup>	84.00	1 619 PB5 455 <sup>(Carbon-Brush Set)</sup>	58.00	1 619 PB5 247	18.00

## Vacuum Cleaner

### (Motor)

GAS 11-21	0 601 97A 006	1 609 203 N43	c/w motor	258.00	-----	-----	1 609 203 A33	31.00
GAS 15	3 601 JE5 000	1 619 PA7 307 <sup>(motor housing)</sup>	c/w motor	52.00	-----	-----	1 619 PA7 289	24.99
GAS 12-25 PL	3 601 J7C 1L0	1 619 PB3 212	c/w motor	210.00	-----	-----	1 619 PB3 890	42.00

## Hot Air Gun / Glue Gun

### (Motor)

### (Element)

PHG 530-2	0 603 290 006	1 609 202 617	1 609 202 638	82.00	-----	153.00	1 609 202 612	42.00
PHG 600 CE	0 603 268 842	1 609 202 256	1 609 203 100	101.00	-----	208.00	1 609 201 500	23.00
PHG 600 2 CE	0 603 290 606	1 609 202 611	1 609 202 627	82.00	-----	249.00	1 609 202 612	42.00
PHG 600 CE	0 601 942 142	1 609 202 269	1 609 202 261	95.00	-----	222.00	1 609 202 264	29.00
GKP 200 CE	0 601 950 706	-----	1 600 A00 0PX	-----	-----	143.00	-----	-----
GHG 600-3	0 601 94B 006	1 609 202 617	1 609 203 J91	82.00	-----	124.00	1 609 203 H59	63.00
GHG 630 DCE	0 601 94C 706	1 609 202 611	1 609 203 J99	82.00	-----	241.00	1 609 203 L51	344.00
GRW 12 E	3 601 AA7 000	1 604 010 B1U	1 604 220 235	430.00	1 607 014 17A	257.00	1 607 200 313	77.00
GHG 650 LCE/-2 LCE	0 601 943 706	1 609 202 611	1 609 202 627	82.00	-----	249.00	1 609 202 612	42.00
GHG 18-60	3 601 BA6 1L0	1600 A01 N63	1 600 A01 N69	66.00	-----	164.00	-----	-----
GHG 20-60	3 601 BA6 2L0	1600 A01 N64	1 600 A01 N6C	66.00	-----	164.00	-----	-----

Valve Malaysia and white

## Carbon Brushes

1. Please be informed that the below chart shown indicate the carbon brushes that comes in 2 different part numbers.
2. Part number on the left column comes in plastic bag; Part number on the right column comes in carton box.
3. Both the number are similar and could be used on the same tool.

No	Ten Digit Number in plastic bag	Ten Digit Number in box (Universal Version)	No	Ten Digit Number in plastic bag	Ten Digit Number in box (Universal Version)	No	Ten Digit Number in plastic bag	Ten Digit Number in box (Universal Version)
1	1 607 014 116	1 607 031 226	6	1 617 014 110	1 607 031 229	11	1 617 014 131	1 607 031 243
2	1 607 014 117	1 607 031 234	7	1 617 014 122	1 607 031 225	12	1 617 014 138	1 607 031 245
3	1 607 014 138	1 607 031 221	8	1 617 014 124	1 607 031 235	13	2 604 320 912	1 607 031 228
4	1 607 014 144	1 607 031 244	9	1 617 014 126	1 607 031 227	14	2 604 321 904	1 607 031 239
5	1 607 014 145	1 607 031 223	10	1 617 014 127	1 607 031 230	15	2 604 321 905	1 607 031 222

## LG - Lawn Mower

	Motor	Blade	Switch
ASM 32	F 016 103 627	-----	F 016 103 606
ROTAK 320	F 016 103 298	F 016 L65 515	F 016 103 606
ROTAK 320 ER	F 016 F04 606	F 016 L68 023	F 016 F04 690
ROTAK 370 ER	F 016 F04 505	F 016 L72 363	F 016 F04 517
ROTAK 34 ERGOFLEX	F 016 103 595	F 016 L65 157	F 016 104 162
ROTAK 40 ERGOFLEX	F 016 103 596	F 016 L65 923	F 016 104 371

## LG - Grass Trimmer

Model	Part Number	Motor	Switch	List Price (RM)	List Price (RM)
ART 23 Combi/Easy Trim	3 600 H78 B72/3 600 H78 AL0	F 016 L71 080 (Fan Assembly)	-----	30.00	-----
ART 23 SL	3 600 HA5 070	F 016 F04 558	F 016 F04 559 (24 mtrs cutting line)	20.00	35.00

## High Pressure Cleaner - Aquatak Series. Gun, Extension Tube & Nozzle

	**w/o hose	Hose F 016 F03 119	309.00	*w/o hose	Hose F 016 F03 582	270.00		
Tool Part Number	Trigger/Gun	List Price (RM)	Hose	List Price (RM)	Lance	List Price (RM)	Nozzle	List Price (RM)
AQT 33-11	F 016 F04 796	53.00	F 016 F04 583 (3 mtrs)	46.00	F 016 F05 281	24.00	F 016 L72 551 (2 in 1)	53.00
AQT 35-12 PLUS	F 016 F05 280	53.00	F 016 F05 013 (5 mtrs)	52.00	F 016 F05 281	24.00	F 016 L72 551 (2 in 1)	53.00
AQT 37-13 PLUS	F 016 F05 280	53.00	F 016 F04 585 (6 mtrs)	64.00	F 016 F05 281	24.00	F 016 L72 551 (2 in 1)	53.00
AQT 42-13	F 016 F05 280	53.00	F 016 F04 621 (7 mtrs)	67.00	F 016 F05 281	24.00	F 016 L72 551 (2 in 1)	53.00
AQT 45-14 X	F 016 F04 633	80.00	F 016 F04 667 (8 mtrs)	77.00	F 016 F05 281	24.00	F 016 L72 551 (2 in 1)	53.00
GHP 5-13 C	F 016 L72 097	85.00	F 016 F04 523 (8 mtrs)	164.00	F 016 L72 098 (with nozzle)	106.00	----	----
GHP 5-55	F 016 L73 068	85.00	F 016 F04 523 (8 mtrs)	164.00	F 016 L73 069 (with nozzle)	93.00	----	----
GHP 5-65	F 016 L73 068	85.00	F 016 F04 523 (8 mtrs)	164.00	F 016 L73 281 (with nozzle)	93.00	F 016 L73 282 (with roto nozzle)	164.00
GHP 5-75 X	F 016 L73 068	85.00	F 016 L73 376 (10 mtrs)	212.00	F 016 L73 327 (with nozzle)	93.00	F 016 L73 384 (with roto nozzle)	164.00
EasyAquatak 100	F 016 F05 131	46.00	F 016 F04 583 (3 mtrs)	46.00	----	----	----	----
EasyAquatak 110	F 016 F04 796	53.00	F 016 F04 583 (3 mtrs)	46.00	F 016 F05 281	24.00	----	----
EasyAquatak 120	F 016 F04 796	53.00	F 016 F05 013 (5 mtrs)	52.00	F 016 F05 281	24.00	----	----
UniversalAquatak 125	F 016 F05 280	53.00	F 016 F05 013 (5 mtrs)	52.00	F 016 F05 281	24.00	----	----
UniversalAquatak 130	F 016 F05 280	53.00	F 016 F05 013 (5 mtrs)	52.00	F 016 F05 281	24.00	----	----
UniversalAquatak 140	F 016 L73 832	85.00	F 016 F04 667 (8 mtrs)	77.00	F 016 F05 281	24.00	----	----
UniversalAquatak 150	F 016 L73 832	85.00	F 016 F04 667 (8 mtrs)	77.00	F 016 F05 281	24.00	----	----



## Warranty

This serves to inform you that **all Bosch Power Tools are guaranteed against manufacturing defects for a period of 12 months** from the registered date of purchase (**Bosch Measuring Tools, GHP Range High Pressure Washer, HEAVY DUTY Range Power Tools, Bosch Range Power Tools, Bosch Hot Air Gun, Bosch Batteries and Bosch Charger are entitled to 12 months warranty. Bosch Aquatak High Pressure washer and Garden Tools are entitled to 6 months warranty. Term and Conditions apply**). For the same defect repair within warranty period, a maximum 3 times warranty repair are allowed for Bosch Power Tools, 2 times for Bosch Measuring Tools and Bosch Home & Garden Tools. This guarantee, however, does not cover damage caused by accident, misuse, unauthorized repairs, tampering, normal wear & tear, additions and modifications made to the tool in any manner. In case of complaint, please send the tool, undismantled together with official proof of purchase, i.e. tax invoice or receipt stated with tool's serial no., to Bosch Power Tools Authorised Service Centre.





































## Jaminan

Dimaklumkan bahawa tempoh jaminan untuk **Alat-alat kuasa Bosch akibat kecacatan product semasa pengilangan adalah terhad kepada 12 bulan sahaja** bermula dari tarik pembelian (**Alat Pengukur Bosch, Siri Pencuci Tekanan Tinggi GHP Bosch, Siri HEAVY DUTY Alat-alat Kuasa Bosch, Alat-alat Kuasa Bosch Range, Alat Pengering Bosch, Bateri Bosch dan Pengecas Bateri Bosch Produk tempoh jaminannya 12 bulan. Pembersih tekanan tinggi dan Alat Kebun Tempoh Jaminannya 6 bulan. Tertakluk kepada Terma and Syarat**). Jumlah maksimum pembaikan dalam tempoh jaminan adalah terhad kepada 3 kali sahaja untuk Alat-alat kuasa Bosch, 2 kali sahaja untuk Alat-alat Pengukur Bosch dan Alat-alat Kuasa Halaman Bosch. Tempoh jaminan ini tidak termasuk kerosakan akibat kemalangan, penyalahgunaan, membaikpulih yang tidak diakui, haus yang sepatut ada dan pengubahsuaian yang mengakibatkan kerosakan Alat-alat kuasa tersebut. Bagi sebarang pengaduan, sila hantar Alat-alat Kuasa dan tax invois rasmi atau resit rasmi sebagai bukti pembelian yang dilengkapi dengan nombor siri Alat-alat Kuasa ke Pusat Servis Alat-alat Kuasa Bosch Yang Sah.

## 保证

谨此通知，有关所有博世电动工具享有为期12个月之生产损坏保证，有效期由购买登记日算起（博世测量仪器，博世GHP 高压清洗机系列，博世 HEAVY DUTY系列产品，博世系列电动工具，博世热风机，博世电池及博世充电器享有12个月保证。高压清洗机和园林工具享有6个月保证。须符合条规）。在维修保证期间，博世电动工具享有高达三次维修服务，而博世测量仪器及博世家园电动工具则享有两次维修服务。上述保证并不包括有关电动工具因意外、错误使用、非授权维修、正常的磨损、附加及交换或其他方式所造成的损坏及故障。若有任何投诉，请将阁下完整的电功工具和购买税务发票或付款收据及具备电功工具编号交到您的博世电动工具授权维修中心。

## Key To Symbols

 Electronic Control	 Rotation Stop	 Constant Electronic	 Forward / Reverse Rotation	 Overload Clutch	 Slim Grip	 Inox For a perfect finish on stainless steel	
 Spindle Lock	 Saw Blade Pendulum Action	 Dust Extraction	 Bosch SDS System	 SDS-Plus Tool Holder	 Fine Depth Adjustment	 Distortion-resistant protective guard	
 SDS-Max Tool Holder	 SDS-Plus Quick Exchange System	 SDS-Clic Quick Clamping System	 Velcro Fastening	 Easy Fit	 Kick Back Stop	 Turbo Blower	
 Removable Cable	 Torque Control	 Restart Protection	 Direct Cooling and Additional Air Inlets	 Brushless EC Motor	 Restart Protection	 Intelligent Brake System	
 Drop Control	 Vibration Control	 Auto-Lock	 Woodrazor	 Turbo Power	 Laser Class 2	 Laser Class 3R	 XLOCK

While all care has been taken to ensure that the information contained in this publication is correct, no responsibility can be accepted for any inaccuracy. The Company reserves the right to alter or modify the information contained herein at any time in light of technical or other developments. Technical specification are valid under normal operating condition only. The company does not accept any responsibility for any misuse of the product and cannot be held liable for consequential damage.



## Authorised Service Centres



Visit our nearest Authorised Service Centre to service your Bosch Power Tools and to purchase tools spare parts.

**Robert Bosch Sdn Bhd** (220975-V)  
No. 8A, Jalan 13/6, 46200 Petaling Jaya, Selangor Darul Ehsan, Malaysia.  
Tel: +603 - 7966 3000 Fax: +603 - 7958 3838  
[www.bosch-pt.com.my](http://www.bosch-pt.com.my)

 Bosch Service Concept Stores

While all care has been taken to ensure that the information contained in this publication is correct, no responsibility can be accepted for any inaccuracy. The Company reserves the right to alter or modify the information contained herein at any time in light of technical or other developments. Technical specification are valid under normal operating condition only. The company does not accept any responsibility for any misuse of the product and cannot be held liable for consequential damage.

For further enquiries, please contact



Bosch Professional Power Tools and Accessories

 **1 800 880 188**

Mon - Fri 9am - 6pm